

# REAR ROTARY PLOUGH FOR TWO-WHEEL TRACTOR



---

## Instruction manual

---

---

**BERTA FRANCO & C. S.n.c.**

Legal offices and factory:

Fraz. Quartino, 66 - 14042 CALAMANDRANA (AT)

Tel. +39 0141 75149 Fax. +39 0141 75170

---

## INDEX

Introduction – Specific use .....	page 2
Warning signs .....	page 3
General safety and accident prevention .....	page 4
Identification .....	page 6
Setting up the two-wheel tractor .....	page 7
General use and starting up .....	page 8
Technical Information .....	page 10
Parts .....	page 11
Starting work .....	page 12
Maintenance .....	page 14

## INTRODUCTION – SPECIFIC USE

The instruction manual contains information on general use, maintenance, the machine's component parts and safety regulations.

This implement for two-wheel tractors, known as a "rear rotary plough for two-wheel tractor" but referred to herewith as "rotary plough", digs down deep into the earth, turns it and breaks it up ready for sowing.

It is able to work when soil is wet and in the presence of long grass, as the rotor does not become blocked.

The rotary plough is coupled to the two-wheel tractor's power take off by a bolted flange or a quick hitch system.

Like all machines, this implement, when used safely and responsibly, is a quick, efficient and profitable working instrument. To enable you to work in complete safety, read the instructions and safety regulations listed in this manual before using the implement and adhere strictly to them at all times. Correct use and proper maintenance will ensure that this rotary plough works efficiently for its entire lifetime. Careful observation of the indications given will help to prevent any inconvenience that will jeopardise its functionality and its life-span.

It is also extremely important that the contents of this booklet be adhered to.

The Manufacturer declines all responsibility for damage caused by negligence and/or failure to observe the aforementioned regulations. We at BERTA FRANCO & C. s.n.c. remain at your disposal, to ensure prompt and thorough technical assistance, or other services which are necessary to keep the machine in optimum working condition.

Every rotary plough comes complete with a copy of this manual.

**Please take notice that:** The illustrations, technical features and descriptions in this manual are not considered binding by the Manufacturer. The complete or partial reproduction of this publication is strictly forbidden unless otherwise authorised by the Manufacturer.

BERTA FRANCO & C. s.n.c. reserves the right to modify the parts and accessories of the machine in the event of technical improvement or to comply with new legislation. The customer may not claim the right to alteration of a machine sold to him prior to said modifications.

### Guarantee

Please check upon delivery that neither the rotary plough nor its accessories have been damaged during transport and that all the accessories are complete. Any complaints must be sent, in writing, to our offices at Calamandrana within 8 days of delivery. The guarantee is valid for 12 months from the date of purchase and must be validated by the authorised dealer. Repairs carried out under guarantee include faulty materials and the manpower involved in their replacement. All repairs under guarantee will be carried out upon our premises. Transport costs must be borne by the customer.

The guarantee will no longer be considered valid in the following cases:

- ♦ Should incorrect manoeuvre lead to breakage.
- ♦ Should repairs carried out by the customer without the consent of BERTA FRANCO & C. s.n.c. or the installation of non-original spare parts alter the rotary plough in any way and so cause damage.
- ♦ Failure to follow the instructions given in this instruction manual

**WARNING SIGNS**

We recommend that attention be paid at all times to the following signs located on the implement.

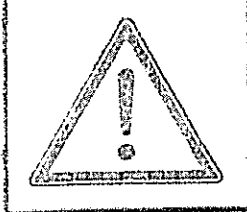
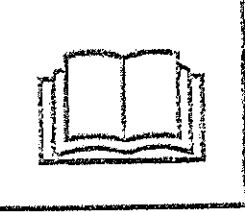
 	<p><b>WARNING</b> Thoroughly read the instruction manual before proceeding with the various operations.</p>
	<p><b>WARNUNG</b> Bevor Sie mit der Arbeit beginnen, lesen Sie sich die Betriebsanleitung aufmerksam durch.</p>
	<p><b>ATTENTION</b> Avant de commencer le travail, lisez attentivement la notice d'instructions.</p>
	<p><b>ATENCIÓN</b> Antes de comenzar a trabajar, lea atentamente el manual de instrucciones.</p>
<p><b>ATTENZIONE</b> Prima di iniziare ad operare, leggere attentamente il libretto di istruzioni</p>	

 	<p><b>WARNING ROTATING ORGANS</b> Stop the engine before any maintenance service. Never put hands or feet under the rotary plough cover while engine is running.</p>
	<p><b>WARNUNG ROTIERENDE TEILE</b> Schalten Sie den motor ab, bevor Sie jegliche wartungsarbeiten vornehmen. Stellen Sie sicher, dass sich ihre hände oder füsse niemals unter der rotierenden pflugabdeckung befinden.</p>
	<p><b>ATTENTION PIÈCES EN MOUVEMENT</b> Arrêtez le moteur avant de procéder à l'entretien. Ne mettez pas les mains ou les pieds sous le coffre charrue-rotatif quand le moteur est en marche.</p>
	<p><b>ATENCIÓN ORGANOS ROTATORIOS</b> Pare el motor antes de realizar cualquier servicio de mantenimiento. No ponga nunca las manos ni los pies bajo la cubierta del arado rotatorio cuando el motor está en movimiento.</p>
<p><b>ATTENZIONE ORGANI ROTANTI</b> Fermare il motore prima di eseguire ogni manutenzione. Non mettere mani o piedi sotto il cofano aratro rotativo quando il motore è in moto.</p>	

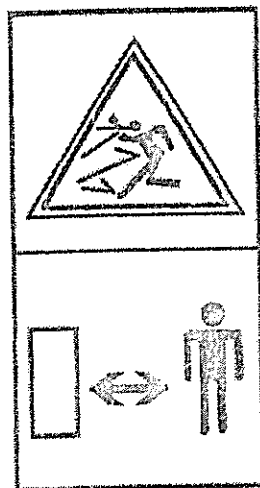

Beware of flying objects. Always remain at a safe distance, the whole body is in danger.

**WARNING:**

Part of the implement, the rotor in the working position to be precise, may not, for obvious reasons, be protected with safety guards. For this reason, we recommend that you pay special attention to the instructions in this manual.



## GENERAL SAFETY AND ACCIDENT PREVENTION

We recommend that you read all the instructions before hitching the rotary plough to the two-wheel tractor. In case of doubt, contact the authorised dealer or our offices at Calamandrana. BERTA FRANCO & C. s.n.c. declines all responsibility for failure to observe the safety and accident prevention regulations and other instructions listed in this instruction manual. As this machine may be used in public areas, the operator must pay special attention to passive safety, especially when working close to roads or pavements.

- 1 – This machine has a series of stickers which highlight the danger points to which special attention must be paid in order to avoid accidents. These stickers are illustrated on page 3 of this manual.
- 2 – Ensure the rotary plough is equipped with the safety guards supplied by the Manufacturer and apply them as indicated in the diagrams.
- 3 – Ensure that the two-wheel tractor to which the rotary plough is hitched is equipped with efficient safety devices, in accordance with the norms in force (e.g.: automatic motor cut-out when both hands release the handlebar, automatic disconnection of the power take off when reversing, etc.). If the above mentioned devices are not present on the two-wheel tractor or do not work properly, the operator may not use it with any implement in complete safety.
- 4 – Never touch any moving parts
- 5 – Adjustments, maintenance and repairs to the machine must always be carried out when the engine is switched off and the two-wheel tractor is locked.
- 6 – Inexperienced persons or those in ill health are strictly forbidden from using the two-wheel tractor with the rotary plough hitched.
- 7 – When working, carrying out maintenance or repairs, wear suitable clothing and protective footwear. Avoid wearing loose clothing, scarves or any other garments, which may become caught in rotating parts.
- 8 – Before starting up the two-wheel tractor and the rotary plough itself, check that all safety devices are in perfect condition.
- 9 – Faulty or missing safety guards must be replaced with original spare parts made by the machine Manufacturer, before starting up.
- 10 – Every time the machine is used, ensure the nuts and bolts, especially those which hold the safety guards in place, are fully tightened.
- 11 – Before switched on the engine, check that the power take off and the two-wheel tractor's gears are in neutral.

- 12– When transporting the two-wheel tractor to the place of work, move slowly. The rotor of the rotary plough must not be activated by the power take off.
- 13– Remember that this type of transport is governed by the road transport norms in force, which must therefore be respected.
- 14– Before starting work, perform some trial runs to gain familiarity with the controls and functions.
- 15– Before using the machine make sure there are no obstacles or foreign bodies in the soil. If there are, they must be removed. If this is not possible, mark the object.
- 16– Upon contact with any obstacle or foreign body, immediately disconnect the power take off and switch off the engine. Then check the machine for damage.
- 17– In the immediate vicinity there is a danger of flying stones and other objects; a danger area of approximately 10 metres around the working area is involved and standing within this area is strictly forbidden. The operator must ensure that neither persons nor animals enter the danger area when he connects the power take off and while he is working. If this occurs he must stop the machine immediately.
- 18– Only the operator in his driving position may enter the danger area. Before moving away from the two-wheel tractor, stop the engine and remove the ignition key from the control panel.
- 19– Before raising the rotary plough from the earth to perform manoeuvres the two-wheel tractor power take off must be placed in neutral so that the rotor stops. If it is necessary to reverse, keep the engine running at the minimum.
- 20– Always switch off the engine before performing adjustments, maintenance or repairs, preventing others from starting the machine. Lock the two-wheel tractor and read the instructions carefully. The machine is equipped with safety guards, which may only be opened using a special tool.
- 21– The stickers bearing the various signs must always be clearly visible, clean and replaced if ruined or difficult to read. (These may be ordered from the Manufacturer).
- 22– When replacing parts, only use the original spares made by the machine Manufacturer: failure to do so will increase the risk of accident and damage and will automatically render the guarantee null and void.
- 23– Respect the conformity of the recommended oil.
- 24– Adhere strictly to the accident prevention measures recommended and described in this manual.
- 25– This manual must be kept and consulted for the entire lifetime of the rotary plough.

**IDENTIFICATION**

Every machine has an identification plate bearing information regarding the:

- Manufacturer
- Type
- Model
- Year of manufacture

Refer to this information when ordering spare parts.

We recommend that you fill in this table with the machine details.

<b>BERTA FRANCO &amp; C. s.n.c</b>	
Frazione Quartino, 66 14042 CALAMANDRANA (AT) Italy	
TYPE	REAR ROTARY PLOUGH FOR TWO-WHEEL TRACTOR
MODEL	AR
YEAR OF MANUFACTURE	
	

## SETTING UP THE TWO-WHEEL TRACTOR

To achieve proper working results from the rotary plough and ensure the stability of the two-wheel tractor, the latter must be set up as follows:  
Ensure the tyres are of the following size: 4.00 - 10, or 5.00 - 10, no less, and that they have an inner width of 36 - 38 cm (following figure).

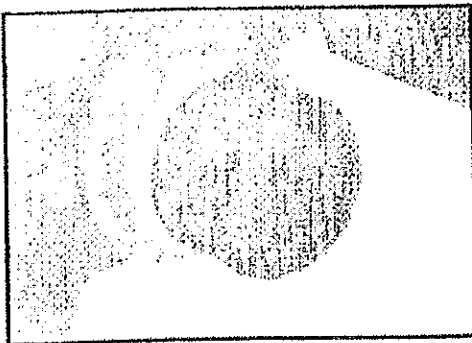
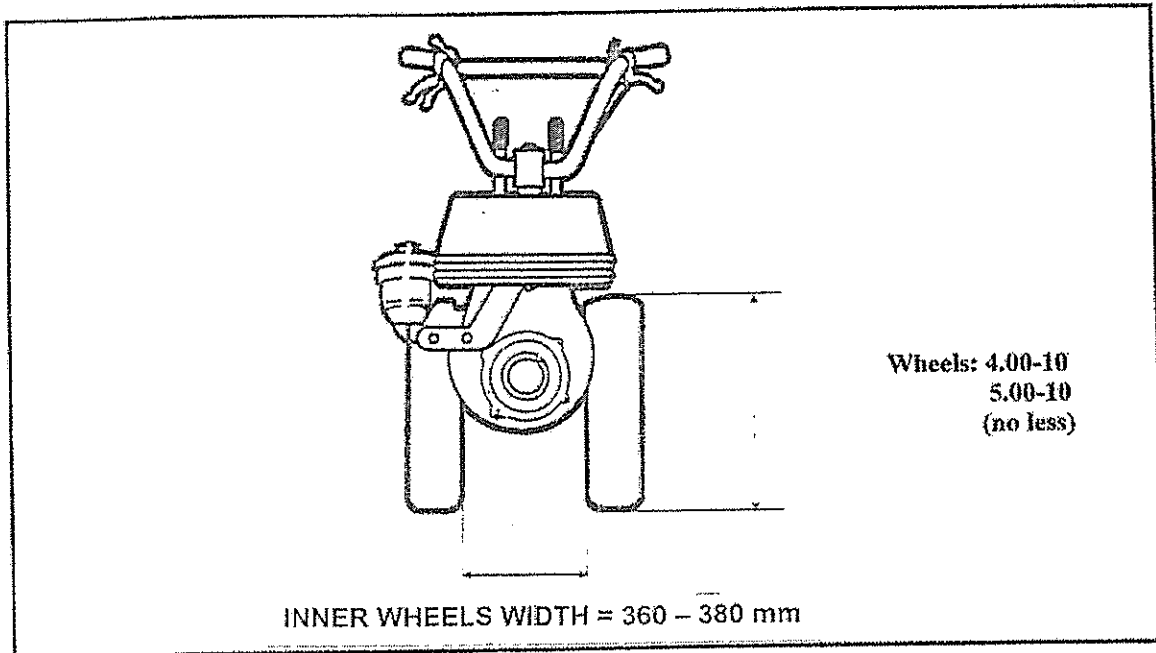

Example of spacer.

Special wheel spacers may be ordered from the two-wheel tractor Manufacturer. (see figure at side).



## GENERAL USE AND STARTING UP

### Before starting up the rotary plough, check the following:

- Check the oil level (see chapter on maintenance);
- Check that all parts subject to wear are in proper working order (e.g.: ploughshares, ploughshare tips, cutting blades, etc.);
- Check the safety guards and ensure that all nuts and bolts are properly tightened;
- Ensure that the lateral safety bar (yellow) is properly secured to the safety guard. If this is packed separately for transport reasons, fit it according to the following instructions:

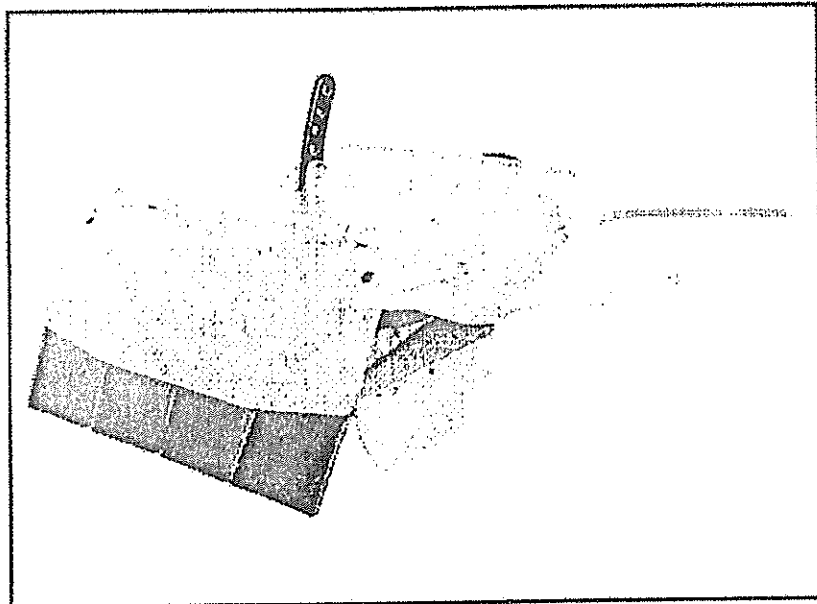

The yellow bar acts as a barrier in case the operator's legs come too close to the side of the implement which, for obvious reasons regarding the discharge of soil, may not be protected with safety guards. **The implement may only be used when this safety device has been correctly fitted.**

#### ASSEMBLY INSTRUCTIONS:

The yellow bar must be fitted to the side of the safety guard where the soil is discharged. Fasten the two ends of the bar to the two holes on the side of the safety guard using the bolts provided (see previous figure).

## Hitching to the two-wheel tractor

1. The rotary plough must always be hitched to the two-wheel tractor on a horizontal surface, never on a slope.
2. Before hitching or unhitching the rotary plough to or from the power take off connection, place the control lever of the latter in neutral.
3. Rest the engine of the two-wheel tractor on the ground so the power take off connection is raised.
4. Couple the rotary plough flange to the two-wheel tractor flange using fully tightened bolts or, if the coupling system is a rapid hitch one:
  - Lift the locking cylinder;
  - Insert the rotary plough pin as far as it will go;
  - Lower the locking cylinder, ensuring that it locks the coupling properly.

## Balancing the two-wheel tractor

When the implement has been hitched to the two-wheel tractor, ensure the weight of the unit formed is evenly distributed. To make the two-wheel tractor stable and to work properly and safely, the operator, holding the handle bar, must apply force of 11 to 13 Kg in order to raise it. If the implement is too heavy or if it lifts up from the ground (this may occur with heavy engines), balance the two-wheel tractor applying counter-weights, available upon request, as described here. The counter-weighting system consists of iron plates (part 1), which are fastened by two bolts (part 2) to the two holes at the upper side of the cover.

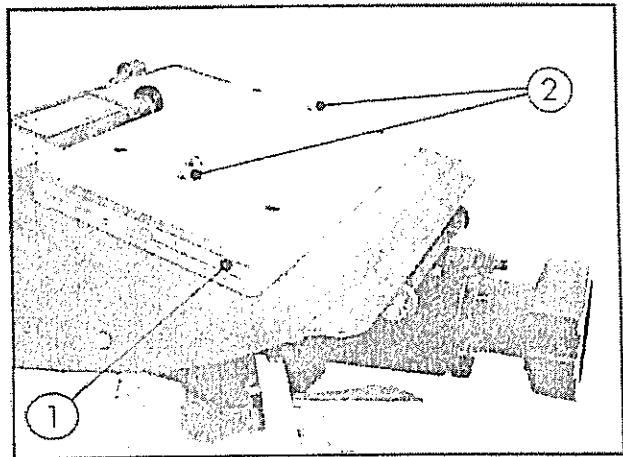

### **IMPORTANT: Use the rotary plough without fatigue !**

If you can not, the reasons are:

- 1) Right balancing is needed. (page 9)
- 2) Wheels diameter and port (inner width) setted not as suggested. (page 7)
- 3) Lack of maintenance of the ploughshare side profile and tip. (page 14)

## Unhitching from the two-wheel tractor

1. The rotary plough must always be unhitched from the two-wheel tractor on a horizontal surface, never on a slope.
2. Rest the implement on the ground, loosen the flange bolts, incline the two-wheel tractor until it touches the ground and uncouple.
 

Or, if the coupling system is a rapid hitch one:

  - Lift the locking cylinder;
  - Extract the rotary plough pin.

TECHNICAL DATA
----------------

<b>Machine type: rear rotary plough for two-wheel tractor</b>		
Model: A R		
Working depth	cm	25 - 30
Absorbed power	HP/CV	8
Dimensions (length, width, height)	cm	66 x 50 x 48
Forward speed	Km/h	1 - 2
Weight	Kg	43
<b>Accessories provided</b>		
Support wheel : for adjusting depth		
<b>Optional accessories</b>		
Side guard: for working without a furrow		
Base plate counter-weight		
Additional counterweight plate		

## PARTS

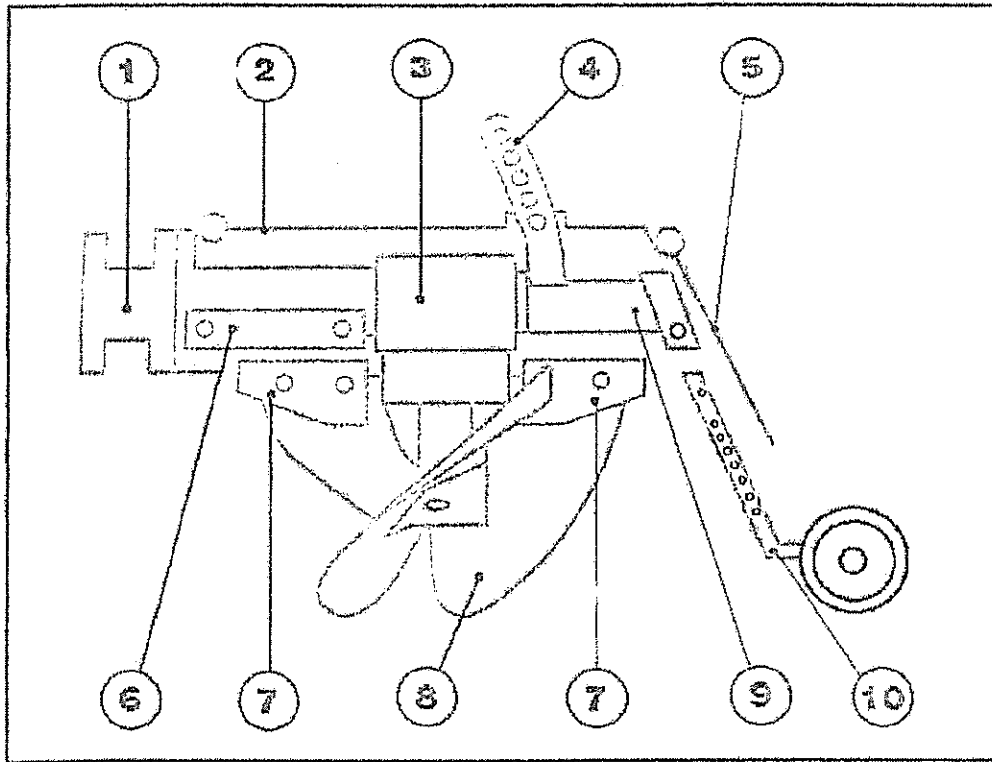

## Key

1. Flange or quick hitch system for hitching to the two-wheel tractor.
2. Main guard in flexible metal sheeting.
3. Main body of the implement with bevel gear.
4. Perforated sector for adjusting the height of the main guard.
5. Jointed rear guard.
6. Fixed cutter blade.
7. Rotating cutter blade.
8. Ploughshare.
9. Rear support for support wheel.
10. Support wheel.

## STARTING WORK



### WARNING

- Avoid allowing the rotary ploughshares to rotate idly when raised above the earth.
- Before raising the implement from the ground to perform manoeuvres, it is **obligatory** to put the power take off in neutral
- When working, the rotating ploughshares may throw up stones or other objects. Always ensure that no persons or animals enter the working range of the rotary plough. This danger also exists for the operator (see safety and accident prevention regulations at page 5).
- Depending on the type of ploughing that one wishes to achieve, evaluate the type of earth (sandy, clay, etc.), and the forward speed.

#### To obtain the maximum working depth

Fasten the main guard to the highest hole on the perforated section (See part 1 on the figure at the side). This facilitates the lateral discharge of the ploughed earth.

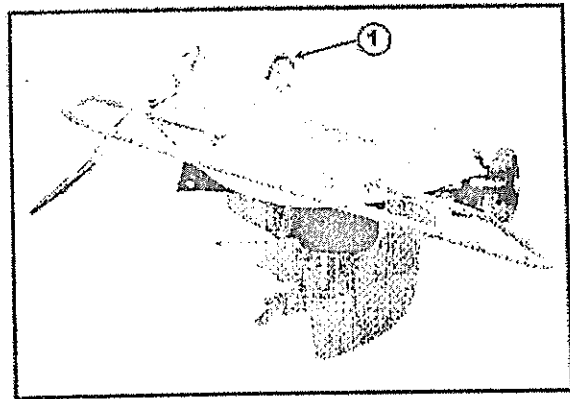

#### To achieve a result without furrows

Fasten the main guard to the lowest hole on the perforated sector (see part 1 on figure at the side) and attach the side guard (part 2) to the side where the earth is discharged using the two bolts which hold the lateral guard in place. The lateral guard is available to order.

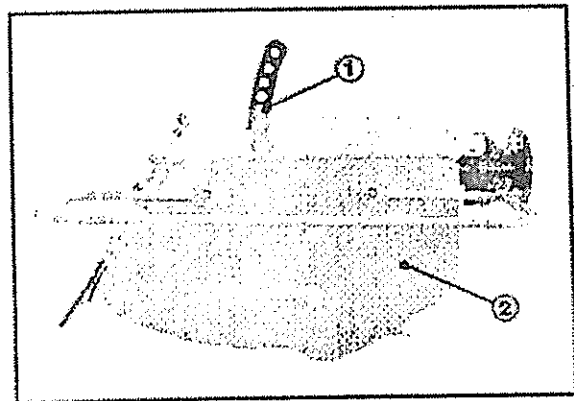

The working depth is adjusted by means of the support wheel connected to the rear support of the rotary plough. Insert the knuckle pin with the flexible retainer into the hole in the support (see fig. at side part 1) and into one of the holes on the support wheel bar (2) to obtain the working-depth required, or into the highest hole on the bar (3) for the transport position (this prevents the rotor from touching the ground).

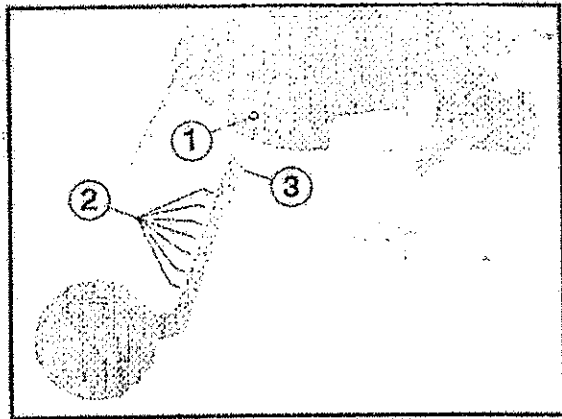

When the knuckle pin has been inserted into the hole on the bar, fasten the relative flexible retainer to prevent it sliding out (as in figure at side).

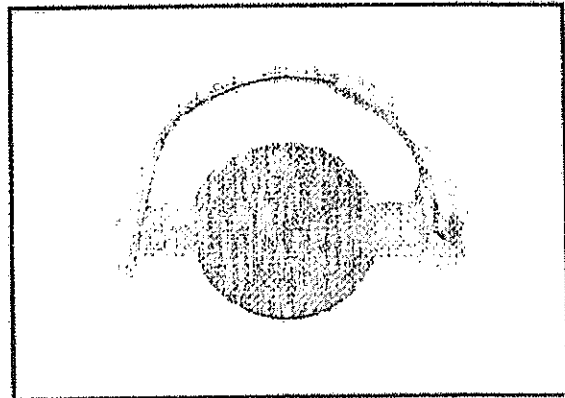

In stony ground it is necessary to remove the cutter blades, both the fixed one on the main body (part 1 on figure at side), and the two rotating ones on the rotor (part 2). The support wheel (part 3) must also be removed. Proceed with the engine at the minimum in order to reduce the danger of flying stones and to avoid repeated blockage of the machine.

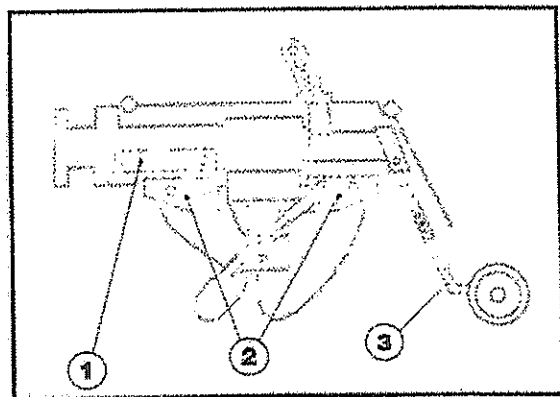

## MAINTENANCE

Properly performed, regular maintenance will keep the machine in good working order and is necessary to safety:

### Ploughshare maintenance

The part of the ploughshare which suffers most wear (the tip), is composed of an interchangeable steel INSERT (part 8 on figure at side), which is much stronger than the rest of the share. This parallelepiped insert may be used on all four edges and must then be replaced, thus preserving the share which will need replacing much later. When the first edge (1) is worn, when it is rounded, unscrew the two bolts (6) which fasten the insert to the ploughshare, turn the insert by 180° and refasten it with the nuts facing upwards. Now use edge (2). To use the remaining edges (3 and 4), turn the insert upside down. After replacing the insert several times, check the side profile of the ploughshare, which was initially blunt, is not too rounded. If so, remove it by unscrewing the fastening screws (5) and restore it to its original bluntness along line 7, using a normal abrasive disc.

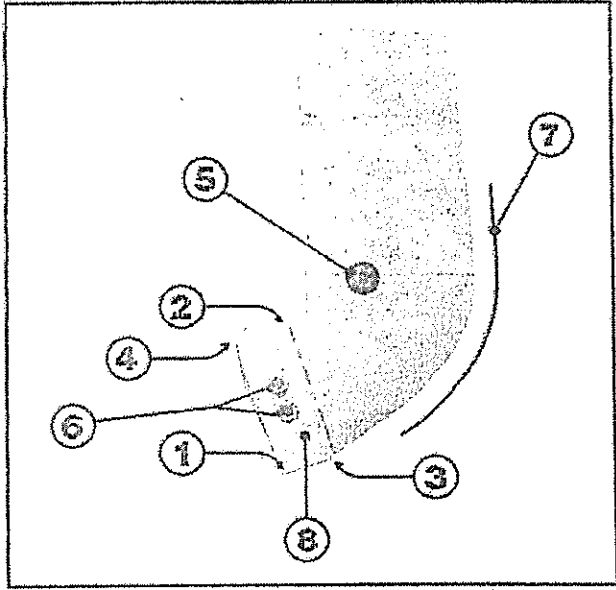

### Lubrication

Check the oil level every 100 hours of work: with the implement positioned so the rotor axle is vertical, unscrew the red cap (part 1 of figure at side) located on the main body of the rotary plough. Check that the oil comes out of the hole in the cap; if this does not happen, add SAE 80-90 gearbox oil.

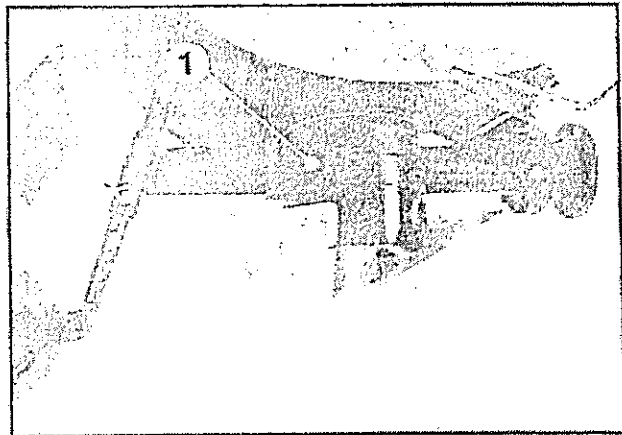

### **Dismantling due to deterioration and/or obsolescence.**

At the end of the machine's life cycle, it must be demolished and it is important to consider the type and composition of the materials to be broken up:

1. Ferrous materials, those composed exclusively of metal, being secondary raw materials, must be taken to registered iron collection yards, after the substances listed in subsection 3 have been
2. plastics and rubber materials, being classed as comparable to urban waste in accordance with community law, may be taken directly to the public refuse department.
3. exhaust oils being classed as special waste and as a result, their collection, transport and disposal must be entrusted to the special department designated.

**TAKE NOTICE:** as the legislation governing waste disposal is continually being changed and updated, the user must keep up to date with the regulations in force when the machine is demolished. Future regulations could differ from those listed above, which are purely informative and general.

BERTA FRANCO & C. s.n.c. remains at your disposal should you require further information, spare parts or technical assistance.



Berta Franco & C. S.n.c.  
 Berta PLOUGH single version  
 EXPLODED VIEW - PAGE 1/1  
 Vers. Dec. 2001 - English

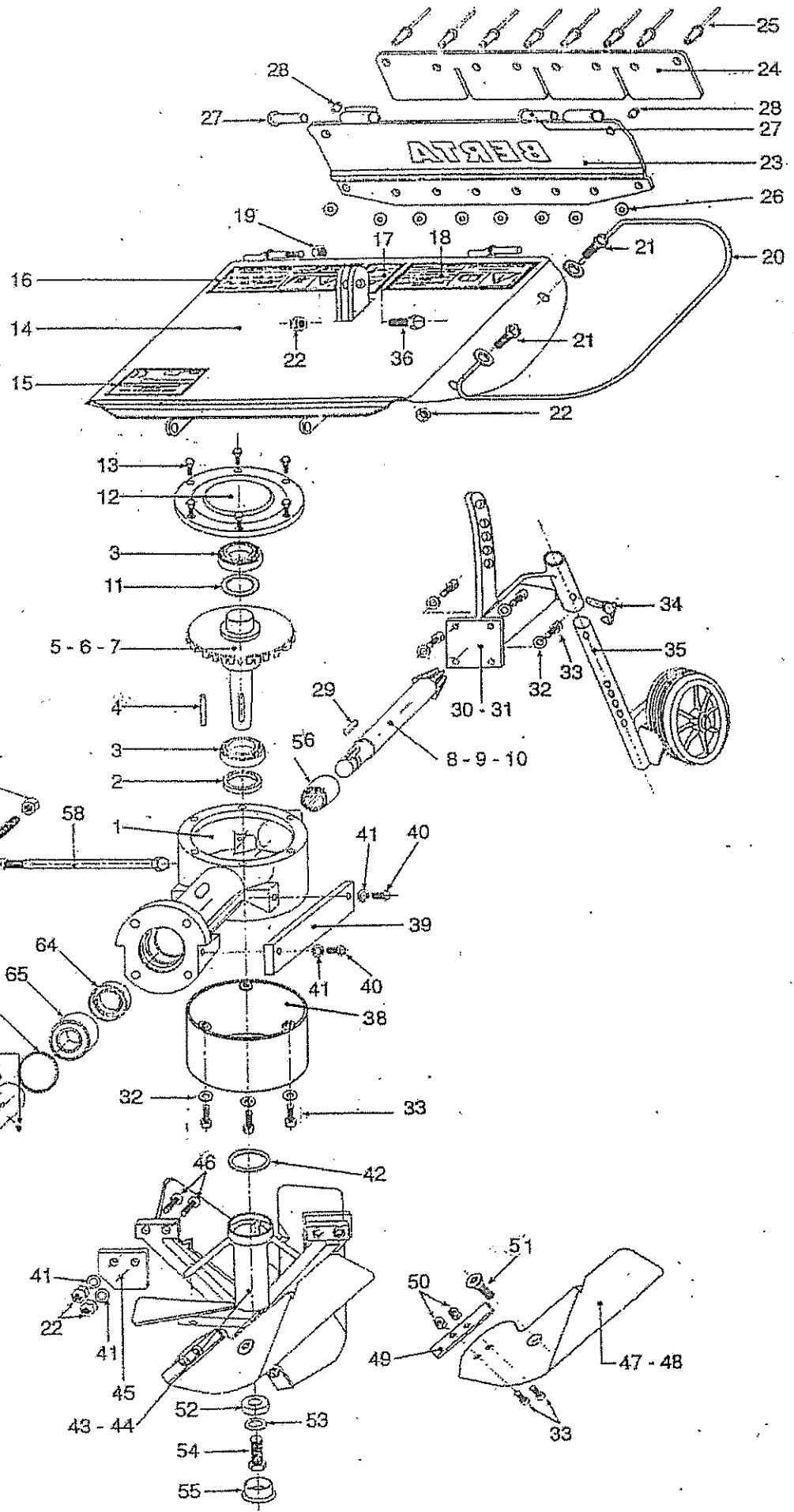

Pos.	DESCRIPTION	Code spare	Qnt	Pos.	DESCRIPTION	Code spare	Qnt
1	GEAR BOX	10001	1	40	HEXAGON HEAD SCREW M10x25 - DIN 933	2008	2
2	OIL RETAINER 30x45x8	6004	1	41	INNER DENTICULATE WASHER FOR Ø10 - DIN 6798 J	4007	6
3	TAPER ROLLER BEARING 30206	5010	2	42	FELT WASHER	10020	1
4	KEY-SPLINE	10017	1	43	HUB SUPPORTING PLOWSHARE (right-hand) read note	10010	1*
5	Vertical shaft with gear wheel Z=32 teeth read note	10021	1*	44	HUB SUPPORTING PLOWSHARE (left-hand) read note	10011	1*
6	Vertical shaft with gear wheel Z=27 teeth read note	10022	1*	45	ROTATING BLADE FOR GRASS CUTTING	10013	2
7	Vertical shaft with gear wheel Z=20 teeth read note	10023	1*	46	FLAT AND SOCKET HEAD SCREW M10x35 DIN 7991	2701	4
8	PINION GEAR Z= 8 TEETH read note	10024	1*	47	RIGHT-HAND PLOWSHARE	10014	4
9	PINION GEAR Z= 9 TEETH read note	10025	1*	48	LEFT-HAND PLOWSHARE	10015	4
10	PINION GEAR Z= 10 TEETH read note	10026	1*	49	CHANGEABLE TIP	10016	4
11	SHIM ADJUSTMENT RING 30,5x50x0,1	10018	1	50	NUT M8 (high thickness) UNI 5587	3004	8
12	GEAR BOX COVER	10002	1	51	FLAT AND SOCKET HEAD SCREW M12x35 DIN 7991	2702	4
13	HEXAGON HEAD SCREW M8x25 - DIN 933	2003	6	52	WASHER 12x35x10,5	10027	1
14	MAIN PROTECTION COVER	10003	1	53	INNER DENTICULATE WASHER FOR Ø12 - DIN 6798 J	4008	5
15	LABEL PRODUCT IDENTIFICATION CE	10012	1	54	HEXAGON HEAD SCREW M12x35 - DIN 933	2021	1
16	LABEL "warning rotating organs"	1004	1	55	PLASTIC CAP	8007	1
17	LABEL "keep distance"	1005	1	56	NEEDLE BEARING NK 28/20	5011	1
18	LABEL "read instruction manual"	1013	1	57	HINGE FOR MAIN COVER PROTECTION	10028	1
19	SELF-LOCKING NUT M10 (low thickness) DIN 985	3501	1	58	HEXAGON HEAD SCREW M12x200 - DIN 931	2021	1
20	ROD IRON FOR LATERAL SAFETY GUARD	10019	1	59	SELF-LOCKING NUT M12 (high-thickness) DIN 982	3506	1
21	HEXAGON HEAD SCREW M10x20 - DIN 933	2010	2	60	STUD BOLT M12x80	8008	2
22	NUT M10 (high thickness) DIN 5587	3003	7	61	NUT M12 (high thickness) UNI 5587	3005	2
23	REAR ARTICULATED COVER	10004	1	62	NUT M12 (middle thickness) DIN 934	3006	2
24	RUBBER GUARD	10005	1	63	HEXAGON HEAD SCREW M12x30 - DIN 933	2022	2
25	RIVET DIN 7337 Ø 3,9x12	7019	8	64	OIL RETAINER 28x47x10	6006	1
26	WASHER 4,5x16x1,5	4006	8	65	BEARING 6205 2RS 25x52x16	5005	1
27	RUBBER BUSH	9035	2	66	O-RING 3187	7017	1
28	RUBBER BUFFER	8005	2	67	GRUB-SCREW M8x10 DIN 914-45H	7016	3
29	KEY-SPLINE 6x6x25	7018	1	68	COUPLING BOX	read note	1
30	REAR RIGHT-HAND SUPPORT read note	10006	1*	69	FLANGE	read note	1
31	REAR LEFT-HAND SUPPORT read note	10007	1*				
32	INNER DENTICULATE WASHER FOR Ø8 - DIN 6798 J	4004	7				
33	HEXAGON HEAD SCREW M8x20 - DIN 933	2017	15				
34	FAST PIN Ø 6x45	8006	1				
35	ADJUSTABLE ROD WITH WHEEL	10008	1				
36	HEXAGON HEAD SCREW M10x30 - DIN 933	2020	1				
38	RING FOR GRASS ANTIROLLING UP	10009	1				
39	FIXED BLADE FOR GRASS CUTTING	10012	1				

Pos.	DESCRIPTION - NOTE	Code spare	Qnt	Pos.	DESCRIPTION - NOTE	Code spare	Qnt
5	FOR ROTARY PLOUGH CODE DR4 AND SR4 (*)	10021		69	FLANGE: (FOR BCS TWO-WHEEL TRACTORS)		
6	FOR ROTARY PLOUGH CODE DR3 AND SR3 (*)	10022			TYPE A) FOR BCS MODEL: 715 - 725 - 735 - 737 - 745 - 720 - 730 - 740 - 746	12001	
7	FOR ROTARY PLOUGH CODE DR2 AND SR2 (*)	10023					
8	FOR ROTARY PLOUGH CODE DR4 AND SR4 (*)	10024			TYPE B) FOR BCS MODEL: 755	12002	
9	FOR ROTARY PLOUGH CODE DR3 AND SR3 (*)	10025					
10	FOR ROTARY PLOUGH CODE DR2 AND SR2 (*)	10026			TYPE C) FOR BCS MODEL: 760	12003	
30	FOR ROTARY PLOUGH CODE DR4, DR3 AND DR2 (*)	10006					
31	FOR ROTARY PLOUGH CODE SR4, SR3 AND SR2 (*)	10007					
43	FOR ROTARY PLOUGH CODE DR4, DR3 AND DR2 (*)	10010					
44	FOR ROTARY PLOUGH CODE SR4, SR3 AND SR2 (*)	10011					
68	COUPLING BOX: (FOR BCS TWO-WHEEL TRACTORS) TYPE A) MALE INVOLUTE SPLINE PROFILE 12 TEETH FOR BCS MODEL: 715 - 725 - 735 - 737	11001			(*) : ROTARY PLOUGH CODE DR4 AND ETC. MEANS: "DR" = DESTRO = RIGHT-HAND PTO ROTATION "SR" = SINISTRO = LEFT-HAND PTO ROTATION THE NUMBERS "4", "3", "2" ARE THE GEAR REDUCTION RATIO IN THE GEAR BOX.		
	TYPE B) FRONTAL WITH 3 PLANE TEETH FOR BCS MODEL: 737 - 745	11002					
	TYPE C) FRONTAL WITH 3 POINTED TEETH FOR BCS MODEL: 720-730-740-746-620-630-640-650	11003					
	TYPE D) FRONTAL WITH 3 PLANE TEETH, LONGER THAN TYPE B FOR BCS MODEL: 755	11004					
	TYPE E) FEMALE INVOLUTE SPLINE PROFILE 12 TEETH FOR BCS MODEL: 760	11005					