

DOUBLE STAGE
SNOW THROWER

FOR TWO-WHEEL TRACTOR

Mod. 60 - 70 - 85



Instruction manual

BERTA s.r.l.

Legal offices and factory:

Fraz. Quartino, 66 – 14042 CALAMANDRANA (AT)

Tel. +39 0141 75149 Fax +39 0141 75170

INDEX

Introduction - Specific use	pag. 2
Warning signs	pag. 3
General safety and Accident prevention	pag. 5
Identification	pag. 7
General use and Starting	pag. 8
Technical Data	pag. 12
Parts	pag. 13
Starting work	pag. 14
Maintenance	pag. 15

INTRODUCTION - USE

The instruction manual contains information on general use, maintenance, the machine's component parts and safety regulations.

This tool, named “**double stage snowthrower for two-wheel tractor**”, known herewith as “**snowthrower**”, enables the clearance of fresh or compacted snow from roads and parking areas, etc., throwing it to a distance of roughly 8 -14 m .

The snowthrower is coupled to the two-wheel tractor's power take off by a bolted flange or a quick hitch system.

Like all machines, this implement, when used safely and responsibly, is a quick, efficient and profitable working instrument. To enable you to work in complete safety, read the instructions and safety regulations listed in this manual before using the implement and adhere strictly to them at all times. Correct use and proper maintenance will ensure that the snowthrower works efficiently for its entire lifetime. Careful observation of the indications given will help to prevent any inconvenience that will jeopardise its functionality and its life-span.

It is also extremely important that the contents of this booklet be adhered to.

The Manufacturer declines all responsibility for damage caused by negligence and/or failure to observe the aforementioned regulations. We at BERTA FRANCO & C. s.n.c. remain at your disposal, to ensure prompt and thorough technical assistance, or other services which are necessary to keep the machine in optimum working condition.

Every snowthrower comes complete with a copy of this manual.

Please take note that: The illustrations, technical features and descriptions in this manual are not considered binding by the Manufacturer. The complete or partial reproduction of this publication is strictly forbidden unless otherwise authorised by the Manufacturer.

BERTA FRANCO & C. s.n.c. reserves the right to modify the parts and accessories of the machine in the event of technical improvement or to comply with new legislation. The customer may not claim the right to alteration of a machine sold to him prior to said modifications.

Guarantee

Please check upon delivery that neither the snowthrower nor its accessories have been damaged during transport and that all the accessories are complete. Any complaints must be sent, in writing, to our offices at Calamandra within 8 days of delivery. The guarantee is valid for 12 months from the date of purchase and must be validated by the authorised dealer. Repairs carried out under guarantee include faulty materials and the manpower involved in their replacement. All repairs under guarantee will be carried out upon our premises. Transport costs must be borne by the customer.

The guarantee will no longer be considered valid in the following cases:

- ◆ Should incorrect manoeuvre lead to breakage.
- ◆ Should repairs carried out by the customer without the consent of BERTA FRANCO & C. s.n.c. or the installation of non-original spare parts alter the snowthrower in any way and so cause damage.
- ◆ Failure to follow the instructions given in this instruction manual

WARNING SIGNS

We recommend that attention be paid at all times to the following signs located on the implement.

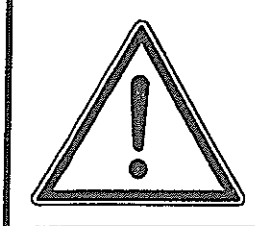
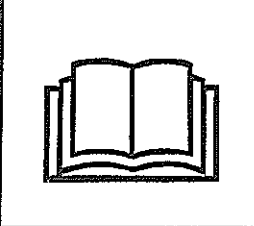
 	<p style="text-align: center;">WARNING</p> <p>Thoroughly read the instruction manual before proceeding with the various operations.</p>
	<p style="text-align: center;">WARNUNG</p> <p>Bevor Sie mit der Arbeit beginnen, lesen Sie sich die Betriebsanleitung aufmerksam durch.</p>
	<p style="text-align: center;">ATTENTION</p> <p>Avant de commencer le travail, lisez attentivement la notice d'instructions.</p>
<p>ATTENZIONE</p> <p>Prima di iniziare ad operare, leggere attentamente il libretto di istruzioni</p>	<p style="text-align: center;">ATENCIÓN</p> <p>Antes de comenzar a trabajar, lea atentamente el manual de instrucciones.</p>

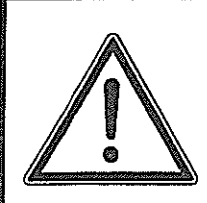
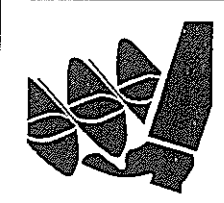
 	<p style="text-align: center;">WARNING ROTATING ORGANS</p> <p>Stop the engine before any maintenance service. Never put hands or feet into the spiral rotor while engine is running.</p>
	<p style="text-align: center;">WARNUNG ROTIERENDE TEILE</p> <p>Shalten Sie den motor ab, bevor Sie jegliche wartungsarbeiten vornehmen. Stellen Sie sicher, dass sich ihre hände oder füsse niemals unter dem schraubenrotor befinden.</p>
	<p style="text-align: center;">ATTENTION PIÈCES EN MOUVEMENT</p> <p>Arrêtez le moteur avant de procéder à l'entretien. Ne mettez pas les mains ou les pieds dans l'hélice quand le moteur est en marche.</p>
<p>ATTENZIONE ORGANI ROTANTI</p> <p>Fermare il motore prima di eseguire ogni manutenzione. Non mettere mani o piedi nel rotore a elica quando il motore è in moto.</p>	<p style="text-align: center;">ATENCIÓN ORGANOS ROTATORIOS</p> <p>Pare el motor antes de realizar cualquier servicio de mantenimiento. No ponga nunca las manos ni los pies en el rotor de hélice cuando el motor está en movimiento.</p>

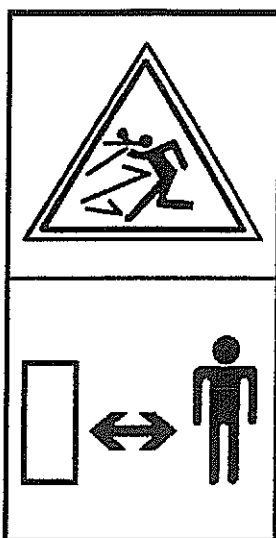

Beware of flying objects.
Always remain at a safe distance, the whole body is in danger.

WARNING:

Part of the implement, the Archimedeian screw and the snow funnel to be precise, may not, for obvious reasons, be protected with safety guards. For this reason, we recommend that you pay special attention to the instructions in this manual.

The following signs illustrate the effect of the two types of snow direction control available to the operator.

FUNNEL ROTATION CONTROL

This is performed using the lever on the handlebar.
The following sign indicating the effects is found at the base of the funnel.

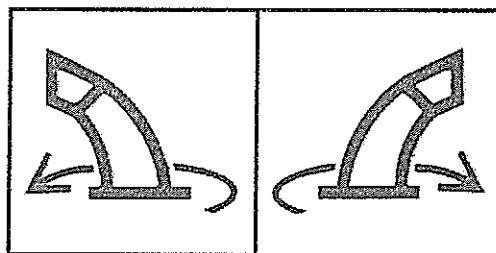

Anti-clockwise rotation:

This corresponds with rotation of the funnel to the left; consequently the snow is thrown to the left.

Clockwise rotation:

This corresponds with rotation of the funnel to the right; consequently the snow is thrown to the right.

UP – DOWN DEFLECTOR CONTROL

This is performed using the grip on the deflector.
The following sign indicating the effects is found beneath the grip.

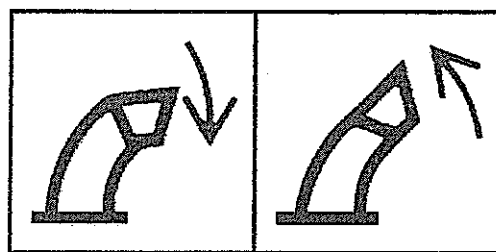

Grip down:

Downward rotation of the grip; consequently the snow falls nearby.

Grip up:

Upward rotation of the grip; consequently the snow falls further away.



GENERAL SAFETY AND ACCIDENT PREVENTION

We recommend that you read all the instructions before hitching the snowthrower to the two-wheel tractor. In case of doubt, contact the authorised dealer or our offices at Calamandrana. BERTA FRANCO & C. s.n.c. declines all responsibility for failure to observe the safety and accident prevention regulations and other instructions listed in this instruction manual. As this machine may be used in public areas, the operator must pay special attention to passive safety, especially when working close to roads or pavements.

- 1 – This machine has a series of stickers which highlight the danger points to which special attention must be paid in order to avoid accidents. These stickers are illustrated on page 3 of this manual.
- 2 – Ensure the snowthrower is equipped with the safety guards supplied by the Manufacturer and apply them as indicated in the diagrams.
- 3 – **Ensure that the two-wheel tractor to which the snowthrower is hitched is equipped with efficient safety devices, in accordance with the norms in force (e.g.: automatic motor cut-out when both hands release the handlebar, etc.). If the above mentioned devices are not present on the two-wheel tractor or do not work properly, the operator may not use it with any implement in complete safety.**
- 4 – Never touch any moving parts
- 5 – Adjustments, maintenance and repairs to the machine must always be carried out when the engine is switched off and the two-wheel tractor is locked.
- 6 – Inexperienced persons or those in ill health are strictly forbidden from using the two-wheel tractor with the snowthrower hitched.
- 7 – When working, carrying out maintenance or repairs, wear suitable clothing and protective footwear. Avoid wearing loose clothing, scarves or any other garments, which may become caught in rotating parts.
- 8 – Before starting up the two-wheel tractor and the snowthrower itself, check that all safety devices are in perfect condition.
- 9 – Faulty or missing safety guards must be replaced with original spare parts made by the machine Manufacturer, before starting up.
- 10 – Every time the machine is used, ensure the nuts and bolts, especially those which hold the safety guards in place, are fully tightened.
- 11 – Before switched on the engine, check that the power take off and the two-wheel tractor's gears are in neutral.

-
- 12 – When transporting the two-wheel tractor to the place of work, move slowly. The rotor of the snowthrower must **not** be activated by the power take off.
 - 13 – Remember that this type of transport is governed by the road transport norms in force, which must therefore be respected.
 - 14 – Before starting work, perform some trial runs to gain familiarity with the controls and functions.
 - 15 – Avoid using the snowthrower on roads or other surfaces the foundation of which are unknown.
 - 16 – Before using the machine, make sure (testing with poles or something similar), that the snow to be moved hides no obstacles and foreign bodies which, if found, must be removed. If their removal is impossible mark them clearly so that they may be avoided.
 - 17 – Upon contact with any obstacle or foreign body, immediately disconnect the power take off and switch off the engine. Then check the machine for damage.
 - 18 – Snow-throwing is the main feature of the snowthrower and as such there is danger from flying stones and other items, as well as snow, extending throughout an area of roughly 25 m. surrounding the jet. For this reason the operator must ensure that neither people nor animals are standing within this area when he switches on the power take off and while he is working, and must stop the machine immediately should the danger zone be entered.
 - 19 – Only the operator in his driving position may enter the danger area. Before moving away from the two-wheel tractor, stop the engine and remove the ignition key from the control panel.
 - 20 – - Always switch off the engine before cleaning the snow funnel and the body of the snowthrower.
 - 21 – When working near to buildings, avoid directing the snow funnel towards the windows.
 - 22 – Always switch off the engine before performing adjustments, maintenance or repairs, preventing others from starting the machine. Lock the two-wheel tractor and read the instructions carefully.
 - 23 – The stickers bearing the various signs must always be clearly visible, clean and replaced if ruined or difficult to read. (These may be ordered from the Manufacturer).
 - 24 – When replacing parts, only use the original spares made by the machine Manufacturer: failure to do so will increase the risk of accident and damage and will automatically render the guarantee null and void.
 - 25 – Respect the conformity of the recommended oil.
 - 26 – Adhere strictly to the accident prevention measures recommended and described in this manual.
 - 27 – This manual must be kept and consulted for the entire lifetime of the snowthrower.

IDENTIFICATION

Every machine has an identification plate bearing information regarding the:

- Manufacturer
- Type
- Model
- Year of manufacture

Refer to this information when ordering spare parts.

We recommend that you fill in this table with the machine details.

BERTA FRANCO & C. s.n.c	
Frazione Quartino, 66 14042 CALAMANDRANA (AT) Italy	
TYPE	DOUBLE STAGE SNOWTHROWER FOR TWO-WHEEL TRACTOR
MODEL	
YEAR OF MANUFACTURE	
	

GENERAL USE AND STARTING

Before starting up the snowthrower, check the following :

- Check the oil level (see chapter on maintenance) ;
- Check that all nuts and bolts are properly tightened ;

Check that the funnel safety guard (part. "A") and the pole for removing obstacles within it (part."B") are included and fitted correctly, as in the figure at the side.

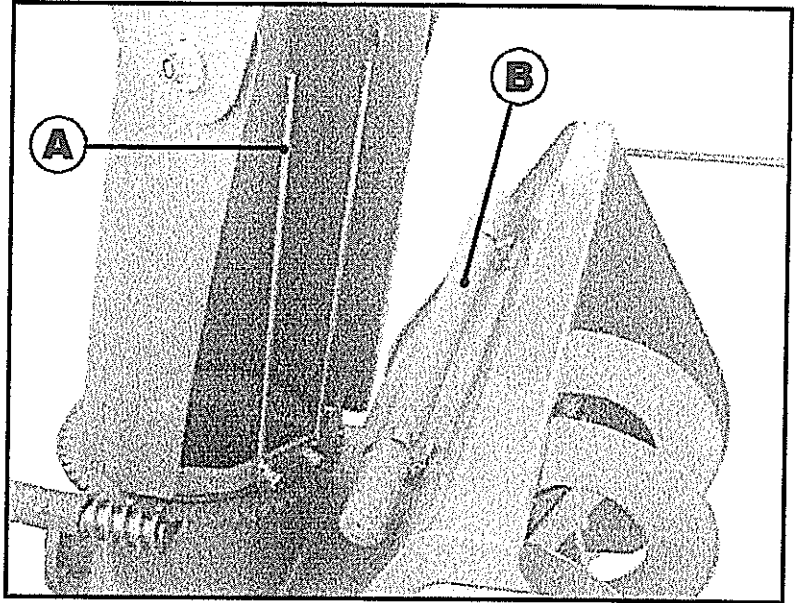

Check that the front safety guard (part.

"C" – yellow bar) is fitted correctly as in the figure at the side; if it is supplied separately for transport reasons, it must be fitted as follows: There are two washers at each end of the yellow bar. These must be fastened, using the bolts supplied (part. "D"), to the two holes on the right and left-hand sides of the snowthrower.

The yellow bar works as a safety barrier in case the legs come too close to the front of the machine which, for obvious reasons, may not be protected using other safety guards.

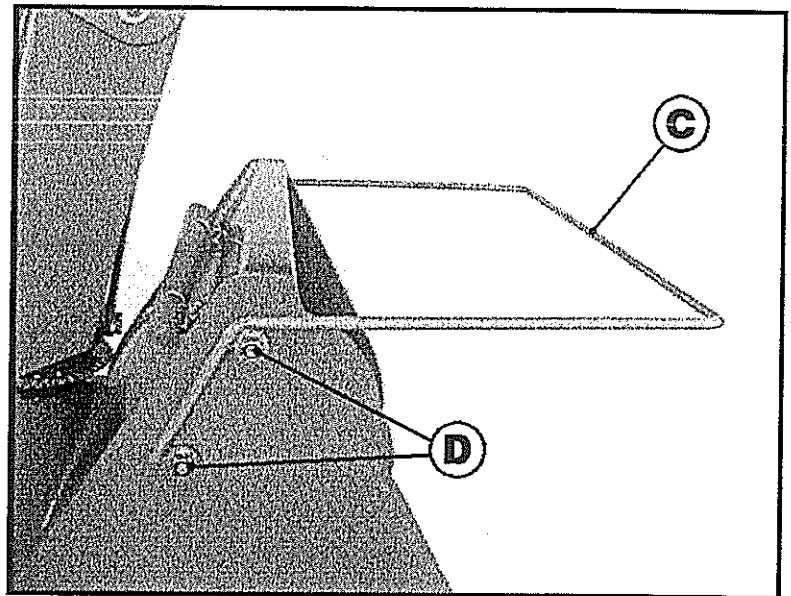

These safety devices must be fitted correctly and used at all times.

* If the snow funnel is supplied separately for transport reasons, fit it according to the following instructions:

At the base of the funnel, beneath the rotation gear to be exact, there are three retainer bolts (see fig. to the side, part. "A"). Remove the three bolts and position the funnel on the required discharge ring. Replace the bolts in the following sequence:

1 – Insert screw "B" from the bottom, upward, screwing it into the gear. Tighten it and lock into place using the self-locking nut "D". Repeat the operation with the two remaining bolts.

2 - Insert screw "C" from the bottom, upwards, screwing it into the gear. Screw "C" regulates the funnel's vertical clearance; the more it is tightened the more clearance is reduced. Regulate the other two bolts in the same way so that the funnel's clearance is neither too great nor too little, making sure that the funnel rotates freely when the handle has been fitted.

3 – Finalise the adjustment by locking self-locking nut "D" onto screw "C". Repeat the same operation with the other two bolts.

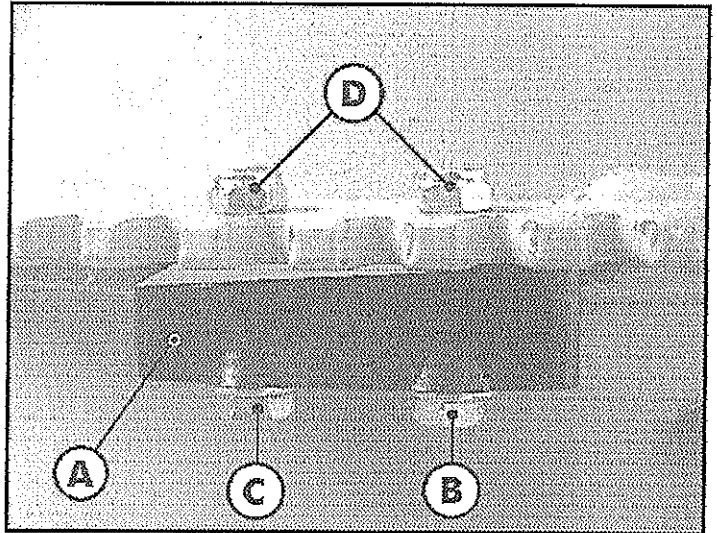

Hitching to the two-wheel tractor

1. The snowthrower must always be hitched to the two-wheel tractor on a horizontal surface, never on a slope.
2. Before hitching or unhitching the snowthrower to or from the power take off connection, place the control lever of the latter in neutral.
3. - Position the snowthrower with the flange raised, placing spacers beneath the rear rotor volute, so that the two flanges fit together when the two-wheel tractor is hitched to the snowthrower.
4. Couple the snowthrower flange to the two-wheel tractor flange using fully tightened bolts or, if the coupling system is a rapid hitch one:

- Lift the locking cylinder;
- Insert the snowthrower pin as far as it will go;
- Lower the locking cylinder, ensuring that it locks the coupling properly.

* Fitting the funnel rotation control lever

The lever (see fig. at side, part. "A") terminates at the opposite end of the grip with a cardan joint, which is bolted to the endless screw (part. "B") using the special screw and nut (part. "C").

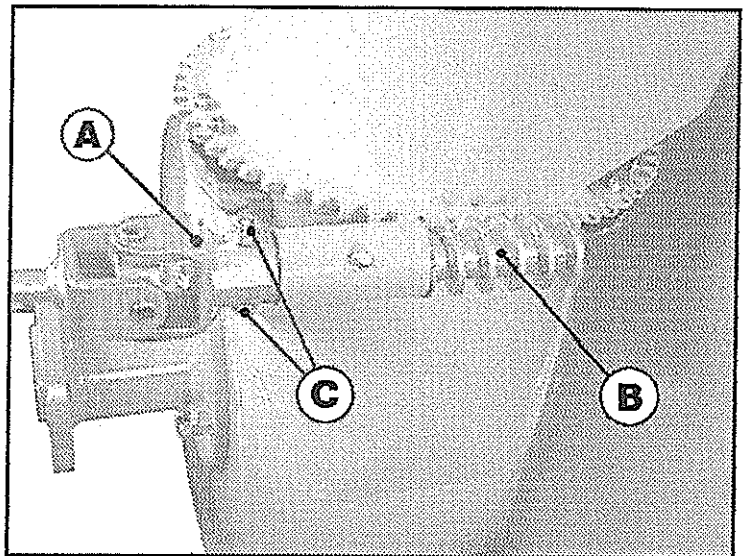

The lever is fastened to the handlebar using the clamp provided, from the grip side; thanks to its universal position, it is possible to fasten the lever in a position that is comfortable for the operator and does not interfere with the two-wheel tractor's other controls.

Adjust the length of the lever, tightening the bolt provided in one of the five available holes (see fig. at side, part. "D")

Tighten the three bolts on the bracket (part. "E"), beginning with that closest to the plastic ball, followed by the two remaining bolts near to the handlebar.

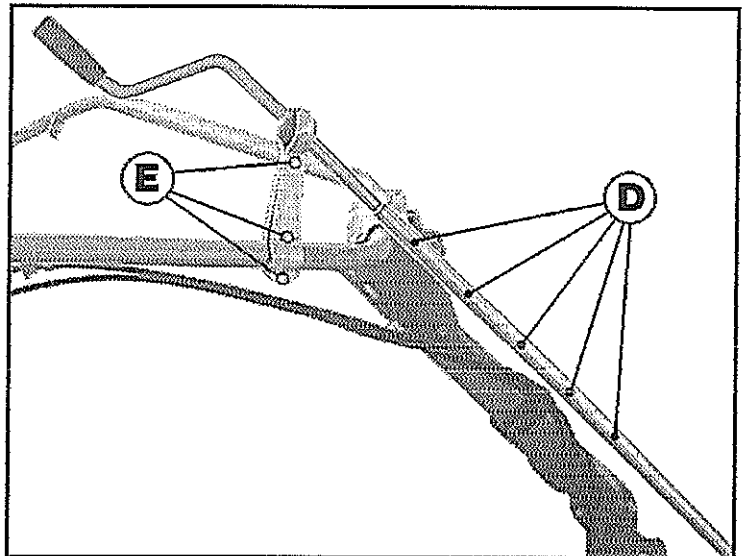

Balancing the two-wheel tractor

Once the tool has been hitched to the two-wheel tractor make sure that the weight of resulting unit is evenly distributed. In order to achieve the required stability and do the job properly, the snowthrower must not lift off the ground when pushing the snow under normal conditions. This may occur when the two-wheel tractor's engine is very heavy. If this is the case contact BERTA FRANCO & C. s.n.c. for further information and advice.

If the snowthrower comes complete with the optional “deflector control wire” accessory, the control of this accessory is positioned on the two-wheel tractor’s handlebar, tightening the two bolts on the bracket (see fig. at side, part. “A”).

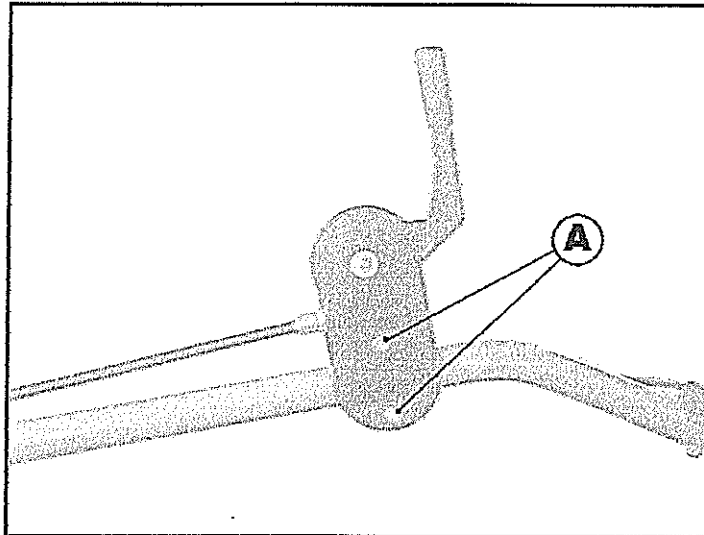

Unhitching from the two-wheel tractor

1. Before performing this operation remove the funnel rotation control lever, carrying out the same procedure as that used for hitching, in reverse.
2. Always unhitch the snowthrower from the two-wheel tractor on a horizontal surface, never on a slope.
3. With the tool resting on the ground loosen the bolts on the flange without removing them completely and place spacers under the rear rotor volute.
4. Once all the bolts have been loosened move the two-wheel tractor away from the snowthrower. Alternatively, if a rapid hitch system is employed:
 - Raise the locking piston;
 - Remove the snowthrower pin.

TECHNICAL DATA

Machine type: Double Stage Snowthrower for Two-wheel tractor			
Model:	“60”	“70”	“85”
Working height (cm)	60	60	65
Working width (cm)	60	70	80
Jet distance (approx. m)	8 - 14	8 - 14	80-14
Funnel rotation (degrees)	200	200	200
Size: width/length/height (cm)	65/67/97	75/67/97	85/67/100
Weight (kg)	64	67	76

COMPONENTS

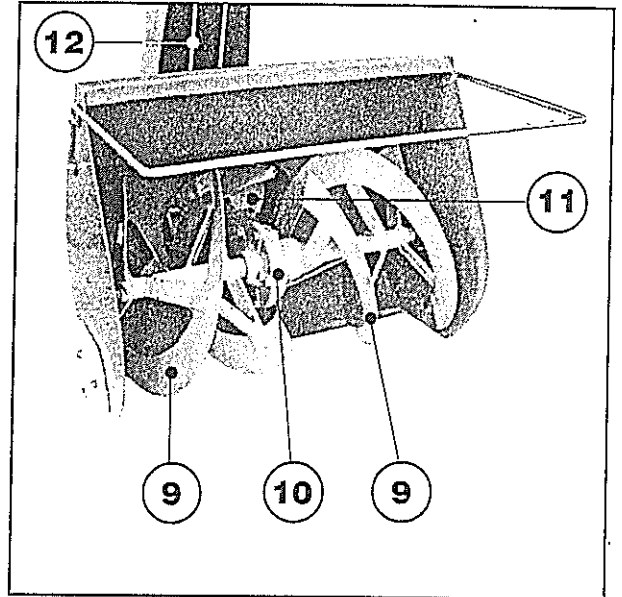
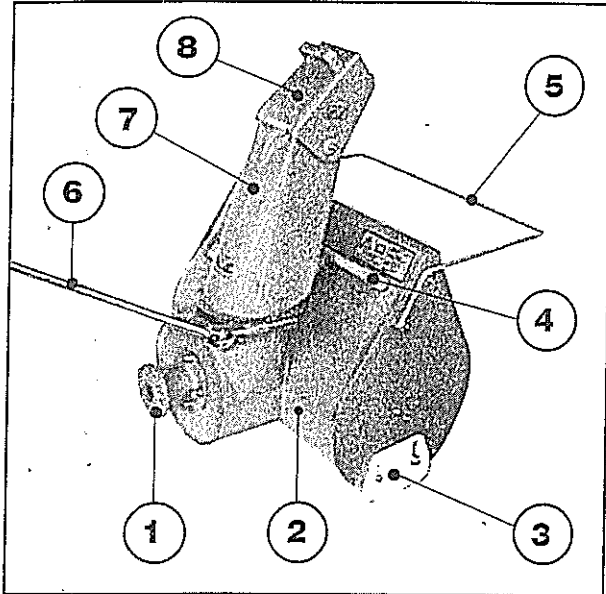

Legend

1. Flange or rapid hitch system for hitching to two-wheel tractor.
2. Main body of the snowthrower.
3. Snowthrower height adjustment slide.
4. Pole for removing blockages.
5. Front safety guard.
6. Funnel rotation lever.
7. Snow funnel.
8. Funnel deflector.
9. Front half-screw.
10. Screw rotation transmission box.
11. Rear rotor.
12. Safety guard for funnel.

STARTING WORK



WARNING

When working, the rotating ploughshares may throw up stones or other objects. Always ensure that no persons or animals enter the working range of the snowthrower. (see safety and accident prevention Regulations at page 5)

Adjusting slide height

The snowthrower's two slides (see fig. below) have three holes for adjusting height and one slot to adapt it to suit the ground surface.

1 – Bolt the slides without fully tightening them, to the hole on the snowthrower in position “1” (as in fig. at side) if the ground is asphalt or concrete. If the ground is gravely or slightly damaged, select position “2” or “3” according to necessity, without fully tightening the bolt.

2 – Loosen the bolt in the slot to enable the slide to adapt to the ground surface.

3 – Fully tighten the two bolts to lock the slide in position

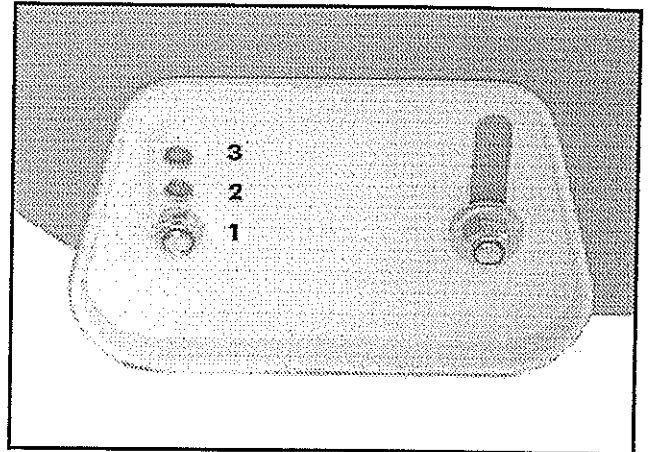

Eliminating obstruction.

Very occasionally the snowthrower may become obstructed. If this happens, and every time cleaning operations are carried out, turn off the engine (remove the key if fitted with electric ignition), clean the snow funnel and the body using the pole supplied or any other suitable means (hot water, broom, etc.).

MAINTENANCE

Replacement of safety bolts

Both the snowthrower's Archimedean screws are equipped with a safety bolt (see fig. below), which breaks if the Archimedean screw comes into contact with a foreign body (stone, brick, etc.), thus avoiding severe damage to the structure and the mechanism.

Two safety bolts are supplied. When replacing them remember that there is a reference phase between the Archimedean screw and its supporting shaft. The Archimedean screw's central pipe (see figure), has two holes placed diametrically opposite one another. The screw goes inside the larger hole after ensuring that there is a surface in line with the shaft below. The self-locking nut is then tightened in the smaller hole. Only original Berta Franco & c. S.n.c. spares must be used to replace the safety bolts. The second stage rotor is protected in a similar fashion with a safety bolt (a spare is provided), even though it is exceptionally rare for it to break.

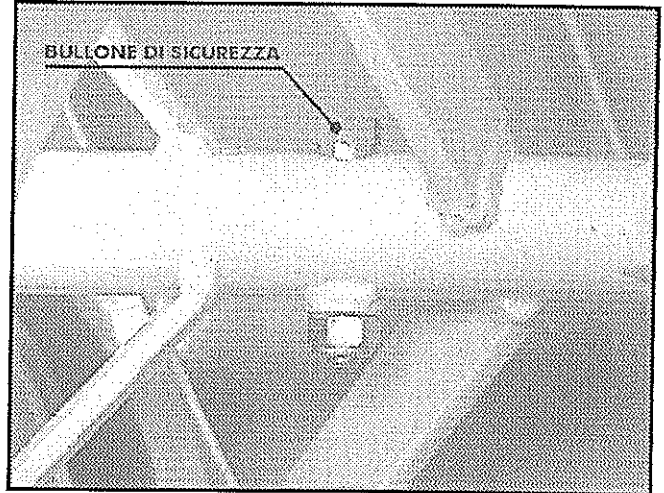

Lubrication

Check the oil level every 100 hours of work: With the snowthrower hitched to the two-wheel tractor and positioned on a horizontal surface, unscrew the red cap located on the main body between the two Archimedean screws (see figure below left). Check that the oil comes out of the hole in the cap; if this does not happen, add **SAE 80-90** gearbox oil.

Check that the base of the rotating funnel and the endless screw are greased. The greasing point for the latter is highlighted by the letter "A" (see figure below right).

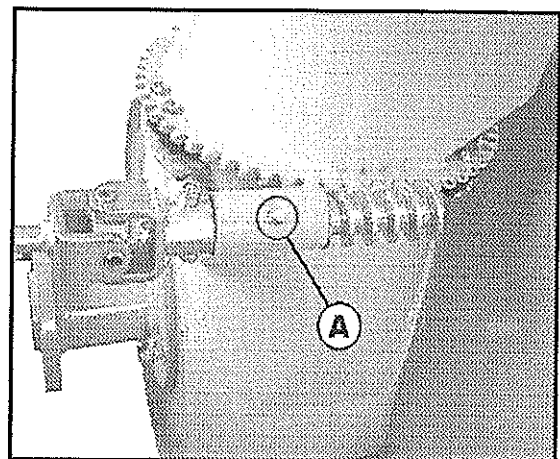

Dismantling due to deterioration and/or obsolescence.

At the end of the machine's life cycle, it must be demolished and it is important to consider the type and composition of the materials to be broken up:

1. Ferrous materials, those composed exclusively of metal, being secondary raw materials, must be taken to registered iron collection yards, after the substances listed in subsection 3 have been recovered.
2. plastics and rubber materials, being classed as comparable to urban waste in accordance with community law, may be taken directly to the public refuse department.
3. exhaust oils being classed as special waste and as a result, their collection, transport and disposal must be entrusted to the special department designated.

Please take note that: as the legislation governing waste disposal is continually being changed and updated, the user must keep up to date with the regulations in force when the machine is demolished. Future regulations could differ from those listed above, which are purely informative and general.

BERTA FRANCO & C. s.n.c. remains at your disposal should you require further information, spare parts or technical assistance.

