

REAR ROTARY PLOUGH FOR TWO-WHEEL TRACTOR

SWIVEL VERSION

CE

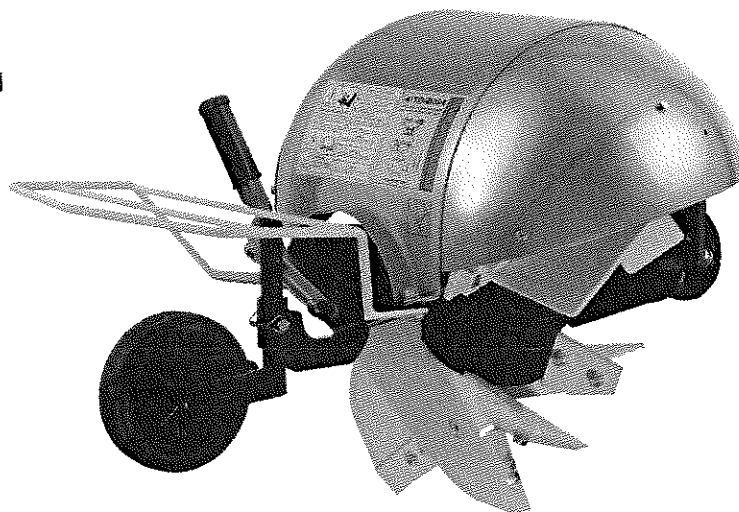

Instruction manual

BERTA s.r.l.

Legal offices and factory:

Fraz.Quartino, 66 – 14042 CALAMANDRANA (AT)

Tel. +39 0141 75149 Fax +39 0141 75170

INDEX

Introduction – Specific use	page 2
Warning signs	page 3
General safety and accident prevention	page 5
Identification	page 7
Setting up the two-wheel tractor	page 8
General use and starting up	page 9
Technical Information	page 11
Parts	page 12
Starting work	page 13
Maintenance	page 14
Spare parts list	

INTRODUCTION – SPECIFIC USE

The instruction manual contains information on general use, maintenance, the machine's component parts and safety regulations.

This implement for two-wheel tractors, known as a “rear rotary plough for two-wheel tractor” – version ARV (swivel), but referred to herewith as “rotary plough”, digs down deep into the earth, turns it and breaks it up ready for sowing.

It is able to work when soil is wet and in the presence of long grass, as the rotor does not become blocked.

The rotary plough is coupled to the two-wheel tractor's power take off by a bolted flange or a quick hitch system.

Like all machines, this implement, when used safely and responsibly, is a quick, efficient and profitable working instrument. To enable you to work in complete safety, read the instructions and safety regulations listed in this manual before using the implement and adhere strictly to them at all times. Correct use and proper maintenance will ensure that this rotary plough works efficiently for its entire lifetime. Careful observation of the indications given will help to prevent any inconvenience that will jeopardise its functionality and its life-span.

It is also extremely important that the contents of this booklet be adhered to.

The Manufacturer declines all responsibility for damage caused by negligence and/or failure to observe the aforementioned regulations. We at Berta S.r.l. remain at your disposal, to ensure prompt and thorough technical assistance, or other services which are necessary to keep the machine in optimum working condition.

Every rotary plough comes complete with a copy of this manual.

NOTA BENE: The illustrations, technical features and descriptions in this manual are not considered binding by the Manufacturer. The complete or partial reproduction of this publication is strictly forbidden unless otherwise authorised by the Manufacturer.

Berta S.r.l. reserves the right to modify the parts and accessories of the machine in the event of technical improvement or to comply with new legislation. The customer may not claim the right to alteration of a machine sold to him prior to said modifications.

Guarantee

Please check upon delivery that neither the rotary plough nor its accessories have been damaged during transport and that all the accessories are complete. Any complaints must be sent, in writing, to our offices at Calamandrana within 8 days of delivery. The guarantee is valid for 12 months from the date of purchase and must be validated by the authorised dealer. Repairs carried out under guarantee include faulty materials and the manpower involved in their replacement. All repairs under guarantee will be carried out upon our premises. Transport costs must be borne by the customer.

The guarantee will no longer be considered valid in the following cases:

- Should incorrect manoeuvre lead to breakage.
- Should repairs carried out by the customer without the consent of Berta S.r.l. or the installation of non-original spare parts alter the rotary plough in any way and so cause damage.
- Failure to follow the instructions given in this instruction manual.

WARNING SIGNS

We recommend that attention be paid at all times to the following signs located on the implement.

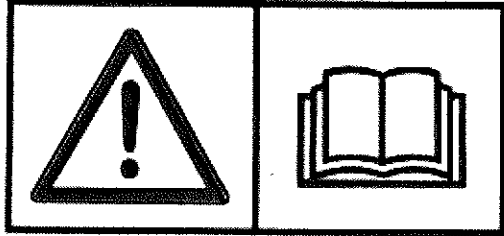
 <p>ATTENZIONE Prima di iniziare ad operare, leggere attentamente il libretto di istruzioni</p>	<p>WARNING Thoroughly read the instruction manual before proceeding with the various operations.</p>
	<p>WARNUNG Bevor Sie mit der Arbeit beginnen, lesen Sie sich die Betriebsanleitung aufmerksam durch.</p>
	<p>ATTENTION Avant de commencer le travail, lisez attentivement la notice d'instructions.</p>
	<p>ATENCIÓN Antes de comenzar a trabajar, lee atentamente el manual de instrucciones.</p>

 <p>ATTENZIONE ORGANI ROTANTI Fermare il motore prima di eseguire ogni manutenzione. Non mettere mani o piedi sotto il cofano aratro rotativo quando il motore è in moto.</p>	<p>WARNING ROTATING ORGANS Stop the engine before any maintenance service. Never put hands or feet under the rotary plough cover while engine is running.</p>
	<p>WARNUNG ROTIERENDE TEILE Schalten Sie den motor ab, bevor Sie jegliche wartungsarbeiten vornehmen. Stellen Sie sicher, dass sich ihre hände oder füsse niemals unter der rotierenden pflugabdeckung befinden.</p>
	<p>ATTENTION PIÈCES EN MOUVEMENT Arrêtez le moteur avant de procéder à l'entretien. Ne mettez pas les mains ou les pieds sous le coffre charrue-rotatif quand le moteur est en marche.</p>
	<p>ATENCIÓN ORGANOS ROTATORIOS Para el motor antes de realizar cualquier servicio de mantenimiento. No ponga nunca las manos ni los pies bajo la cubierta del arado rotatorio cuando el motor está en movimiento.</p>

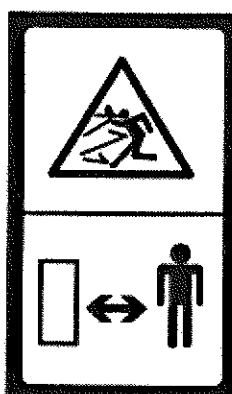

Beware of flying objects.
Always remain at a safe distance, the whole body is in danger.

WARNING:

Part of the implement, the rotor in the working position to be precise, may not, for obvious reasons, be protected with safety guards. For this reason, we recommend that you pay special attention to the instructions in this manual.

The following stickers illustrate the effect of the rotation of the inversion lever and are situated by the two lever locking positions.

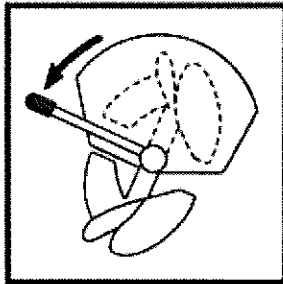

Lever in left-hand position:
the rotor below moves the earth
towards the left.

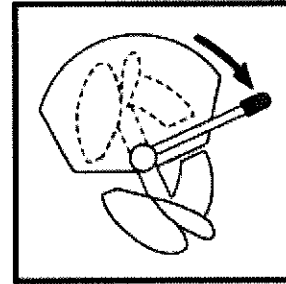

Lever in right-hand position:
the rotor below moves the earth
towards the right.

How to invert the rotors:

- Disconnect the power take off
- Lift the handle bar so that the rotors do not touch the ground when they rotate
- Unlock the lever by pulling it towards you, turn it until it reaches the other position
- Check that the lever locks into the new position.

Warning: if the lever is not in the exact position it will not lock into place.

NEVER ENGAGE THE POWER TAKE OFF WITH THE LEVER UNLOCKED.

**GENERAL SAFETY AND
ACCIDENT PREVENTION**

We recommend that you read all the instructions before hitching the rotary plough to the two-wheel tractor. In case of doubt, contact the authorised dealer or our offices at Calamandrana.

Berta S.r.l. declines all responsibility for failure to observe the safety and accident prevention regulations and other instructions listed in this instruction manual. As this machine may be used in public areas, the operator must pay special attention to passive safety, especially when working close to roads or pavements.

- 1 – This machine has a series of stickers which highlight the danger points to which special attention must be paid in order to avoid accidents. These stickers are illustrated on page 3 of this manual.
- 2 – Ensure the rotary plough is equipped with the safety guards supplied by the Manufacturer and apply them as indicated in the diagrams.
- 3 – Ensure that the two-wheel tractor to which the rotary plough is hitched is equipped with efficient safety devices, in accordance with the norms in force (e.g.: automatic motor cut-out when both hands release the handlebar, automatic disconnection of the power take off when reversing, etc.). If the above mentioned devices are not present on the two-wheel tractor or do not work properly, the operator may not use it with any implement in complete safety.
- 4 – Never touch any moving parts
- 5 – Adjustments, maintenance and repairs to the machine must always be carried out when the engine is switched off and the two-wheel tractor is locked.
- 6 – Inexperienced persons or those in ill health are strictly forbidden from using the two-wheel tractor with the rotary plough hitched.
- 7 – When working, carrying out maintenance or repairs, wear suitable clothing and protective footwear. Avoid wearing loose clothing, scarves or any other garments, which may become caught in rotating parts.
- 8 – Before starting up the two-wheel tractor and the rotary plough itself, check that all safety devices are in perfect condition.
- 9 – Faulty or missing safety guards must be replaced with original spare parts made by the machine Manufacturer, before starting up.
- 10 – Every time the machine is used, ensure the nuts and bolts, especially those which hold the safety guards in place, are fully tightened.
- 11 – Before switched on the engine, check that the power take off and the two-wheel tractor's gears are in neutral.

- 12 – When transporting the two-wheel tractor to the place of work, move slowly. The rotor of the rotary plough must **not be activated by the power take off**.
- 13 – Remember that this type of transport is governed by the road transport norms in force, which must therefore be respected.
- 14 – Before starting work, perform some trial runs to gain familiarity with the controls and functions.
- 15 – Before using the machine make sure there are no obstacles or foreign bodies in the soil. If there are, they must be removed. If this is not possible, mark the object.
- 16 – Upon contact with any obstacle or foreign body, immediately disconnect the power take off and switch off the engine. Then check the machine for damage.
- 17 – In the immediate vicinity there is a danger of flying stones and other objects; a danger area of approximately 10 metres around the working area is involved and standing within this area is strictly forbidden. The operator must ensure that neither persons nor animals enter the danger area when he connects the power take off and while he is working. If this occurs he must stop the machine immediately.
- 18 – Only the operator in his driving position may enter the danger area. Before moving away from the two-wheel tractor, stop the engine and remove the ignition key from the control panel.
- 19 – Before raising the rotary plough from the earth to perform manoeuvres the two-wheel tractor power take off must be placed in neutral so that the rotor stops. If it is necessary to reverse, keep the engine running at the minimum.
- 20 – Always switch off the engine before performing adjustments, maintenance or repairs, preventing others from starting the machine. Lock the two-wheel tractor and read the instructions carefully. The machine is equipped with safety guards, which may only be opened using a special tool.
- 21 – The stickers bearing the various signs must always be clearly visible, clean and replaced if ruined or difficult to read. (These may be ordered from the Manufacturer).
- 22 – When replacing parts, only use the original spares made by the machine Manufacturer: failure to do so will increase the risk of accident and damage and will automatically render the guarantee null and void.
- 23 – Respect the conformity of the recommended oil.
- 24 – Adhere strictly to the accident prevention measures recommended and described in this manual.
- 25 – This manual must be kept and consulted for the entire lifetime of the rotary plough.

IDENTIFICATION

Every machine has an identification plate bearing information regarding the:

- Manufacturer
- Type
- Model
- Serial N.
- Weight
- Year of manufacture

Refer to this information when ordering spare parts.

We recommend that you fill in this table with the machine details.

BERTA s.r.l. Frazione Quartino, 66 14042 CALAMANDRANA (AT) Italy	
TYPE	REAR ROTARY PLOUGH FOR TWO - WHEEL TRACTOR
MODEL	
SERIAL N.	
WEIGHT	kg.
YEAR OF MANUFACTURE	
	

SETTING UP THE TWO-WHEEL TRACTOR

To achieve proper working results from the rotary plough and ensure the stability of the two-wheel tractor, the latter must be set up as follows:

Ensure the tyres are of the following size: **4.00 - 10**, or **5.00 - 10**, no less, and that they have an inner width of **36-38 cm** (following picture).

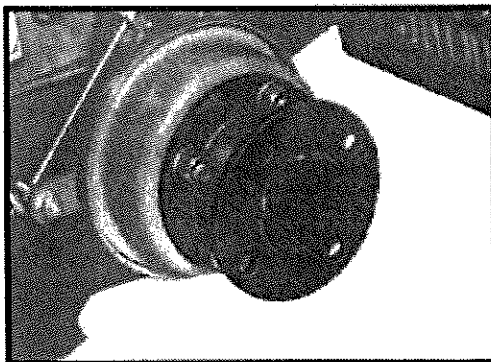
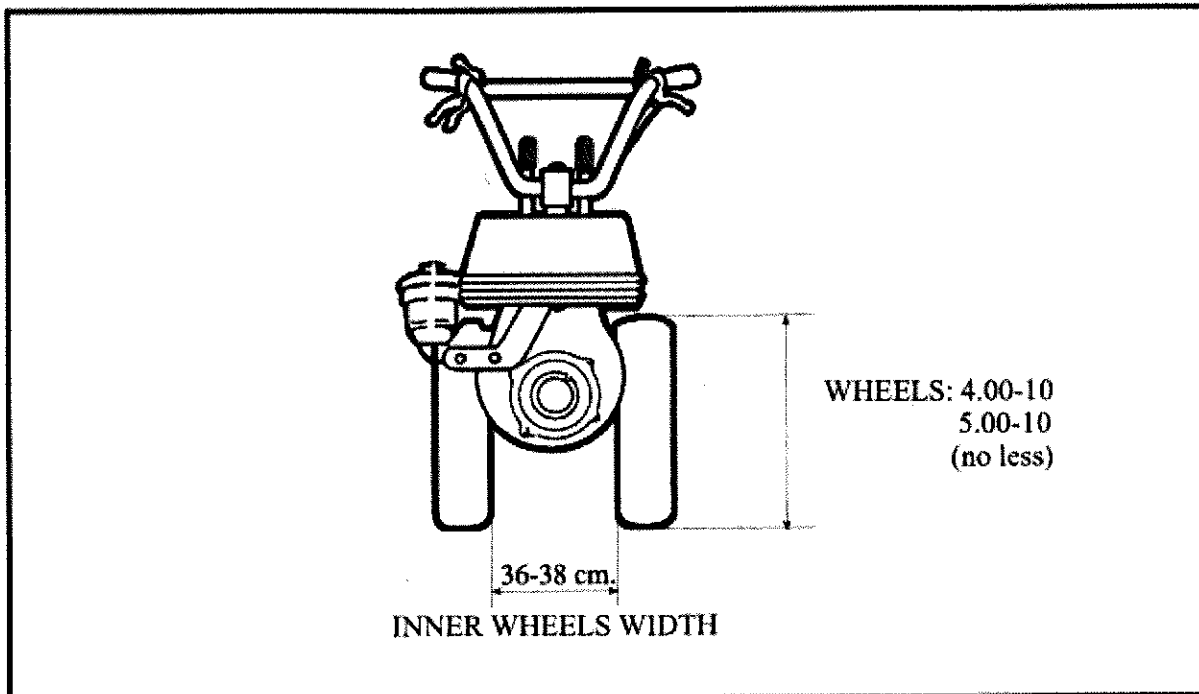

Example of spacer.

Special wheel spacers may be ordered from the two-wheel tractor Manufacturer. (see picture at side).

GENERAL USE AND STARTING

Before starting up the rotary plough, check the following:

- Check the oil level (see chapter on maintenance);
- Check that all parts subject to wear are in proper working order (e.g.: ploughshares, ploughshare tips, cutting blades, etc.);
- Check the safety guards and ensure that all nuts and bolts are properly tightened;
- Ensure that the lateral safety bars (yellow) are properly secured to the safety guard. If these are packed separately for transport reasons, fit them according to the following instructions:

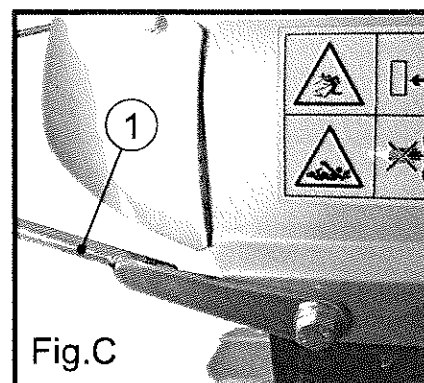
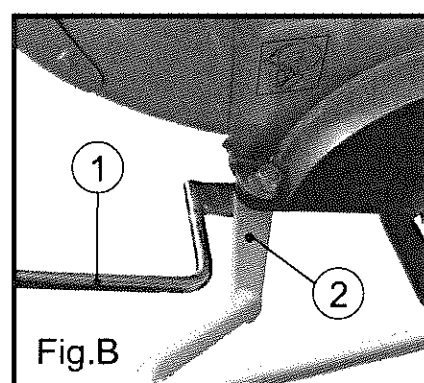
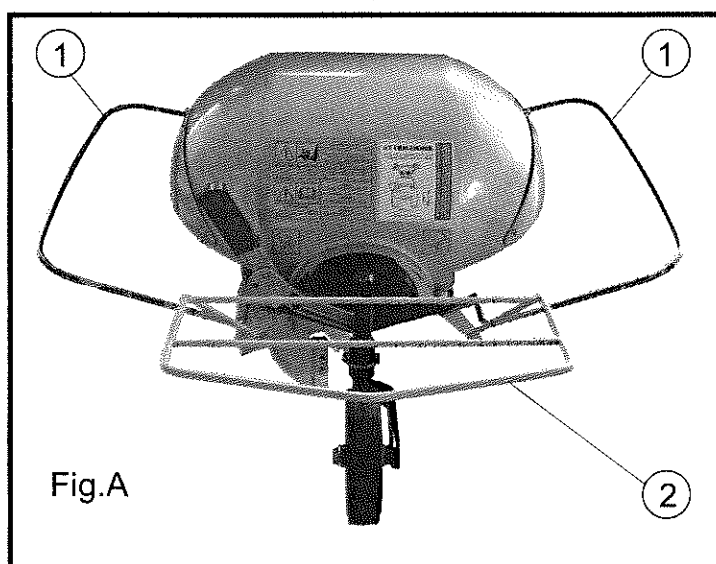

The yellow bars acts as barriers in case the operator's legs come too close to the sides of the implement which, for obvious reasons regarding the discharge of soil, may not be protected with safety guards.

The implement may only be used when these safety devices have been correctly fitted.

ASSEMBLY INSTRUCTIONS:

Two yellow bars are supplied, one for the right-hand side of the implement and one for the left. Each one ends with a hole for fastening with a bolt (provided). Looking at the rotary plough from the lever side (see pict. A), you will see that there are two bolts that hold the safety guard to the structure beneath, by the locking positions of the lever itself. Fasten the ends of the bars using these bolts so that the flat end of the yellow bar overlaps the safety guard (see fig. B). The other two ends of the rods must be fastened to the power take off side, using the two bolts which hold the safety guard to the structure beneath, so that the flat end of the bar overlaps the safety guard (see Fig. C). The rear yellow bar (pict.A, part 2) is a safety spacer for the legs. Fasten the two ending parts of this bar (pict. B part 2) together with the ending parts of the right and left yellow bars (pict. B, part 1).

Hitching to the two-wheel tractor

1. The rotary plough must always be hitched to the two-wheel tractor on a horizontal surface, never on a slope.
2. Before hitching or unhitching the rotary plough to or from the power take off connection, place the control lever of the latter in neutral.
3. Rest the engine of the two-wheel tractor on the ground so the power take off connection is raised.
4. Couple the rotary plough flange to the two-wheel tractor flange using fully tightened bolts or, if the coupling system is a rapid hitch one:
 - Lift the locking cylinder;
 - Insert the rotary plough pin as far as it will go;
 - Lower the locking cylinder, ensuring that it locks the coupling properly.

Balancing the two-wheel tractor

When the implement has been hitched to the two-wheel tractor, ensure the weight of the unit formed is evenly distributed. To make the two-wheel tractor stable and to work properly and safely, the operator, holding the handle bar, must apply force of 5 to 8 Kg in order to raise it. If the force required is different, balance the two-wheel tractor applying counter-weights near to the engine.

Unhitching from the two-wheel tractor

1. The rotary plough must always be unhitched from the two-wheel tractor on a horizontal surface, never on a slope.
2. Rest the implement on the ground, loosen the flange bolts, incline the two-wheel tractor until it touches the ground and uncouple.
Or, if the coupling system is a rapid hitch one:
 - Lift the locking cylinder;
 - Extract the rotary plough pin.

TECHNICAL DATA

Machine type: rear rotary plough for two-wheel tractor		
Model: A RV		
Working depth	cm	25 - 30
Absorbed power	HP/CV	8
Dimensions (length, width, height)	cm	65 x 60 x 60
Forward speed	Km/h	1 - 2
Weight	Kg	67
Accessories provided		
Support wheel : for adjusting depth		

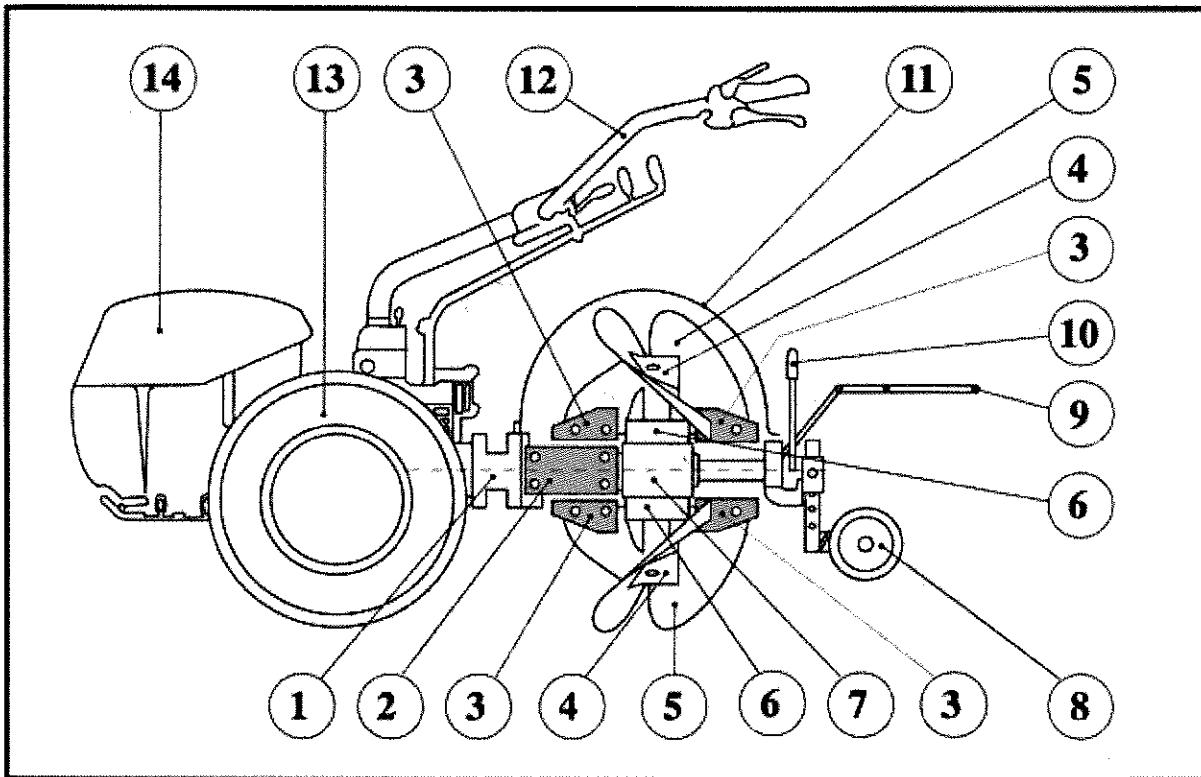
PARTS**KEY**

1. Flange or quick hitch system for hitching to the two-wheel tractor.
2. Fixed cutter blade.
3. Rotating cutter blade.
4. Rotating hub for right-hand ploughshares (each hub supports 4 ploughshares).
5. Right-hand ploughshare.
6. Anti-tangle ring for grass and threads, etc.
7. Main body of the implement with bevel gear.
8. Adjustable support wheel.
9. Rear guard
10. Control lever for unlocking and inverting rotors.
11. Fixed metal guard.
12. Two-wheel tractor handlebar.
13. Two-wheel tractor wheel.
14. Two-wheel tractor engine.

STARTING WORK**WARNING**

- Avoid allowing the rotary ploughshares to rotate idly when raised above the earth.
- Before raising the implement from the ground to perform manoeuvres, it is **obligatory** to put the power take off in neutral
- When working, the rotating ploughshares may throw up stones or other objects. Always ensure that no persons or animals enter the working range of the rotary plough. This danger also exists for the operator (see safety and accident prevention regulations at page 5).

Depending on the type of ploughing that one wishes to achieve, evaluate the type ground (sandy, clay, etc.), and the forward speed.

In sandy ground or with little consistency it is necessary to attach the adjustable support wheel to prevent the implement from sinking into the ground and to adjust the working depth. (see pict. A)

In stony ground it is necessary to remove the rotating cutter blades, (picture B, part. I) on the rotor. Proceed with the engine at the minimum in order to reduce the danger of flying stones and to avoid repeated blockage of the machine.

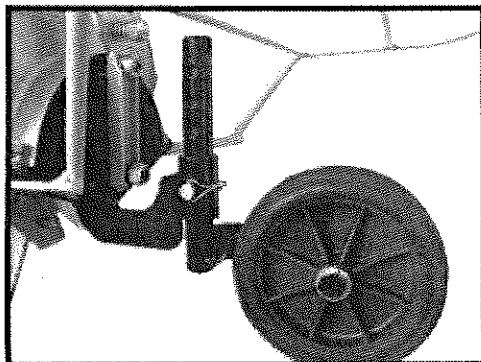
Fig. A

Support wheel for adjusting depth.
Unnecessary in consistent earth.

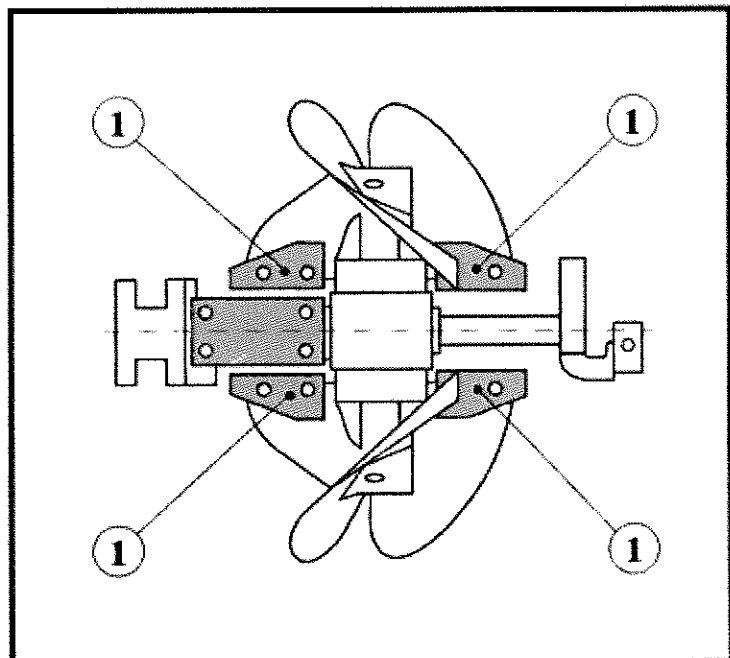
Fig. B

MAINTENANCE

Properly performed, regular maintenance will keep the machine in good working order and is necessary to safety.

Ploughshare maintenance

The part of the ploughshare which suffers most wear (the tip), is composed of an interchangeable steel INSERT (part 8 on picture at side), which is much stronger than the rest of the share. This parallelepiped insert may be used on all four edges and must then be replaced, thus preserving the share which will need replacing much later. When the first edge (1) is worn, when it is rounded, unscrew the two bolts (6) which fasten the insert to the ploughshare, turn the insert by 180° and refasten it with the nuts facing upwards. Now use edge (2). To use the remaining edges (3 and 4), turn the insert upside down. After replacing the insert several times, check the side profile of the ploughshare, which was initially blunt, is not too rounded. If so, remove it by unscrewing the fastening screws (5) and restore it to its original bluntness along line 7, using a normal abrasive disc.

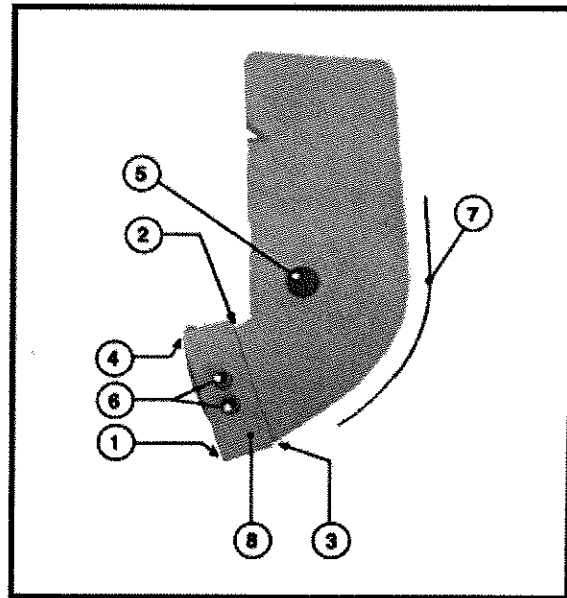

Lubrication

Check the oil level every 100 hours of work: with the implement positioned so the rotor axle is vertical, unscrew the red cap (part 1, picture at side) located on the main body of the rotary plough. Check that the oil comes out of the hole in the cap; if this does not happen, add SAE 80-90 gearbox oil.

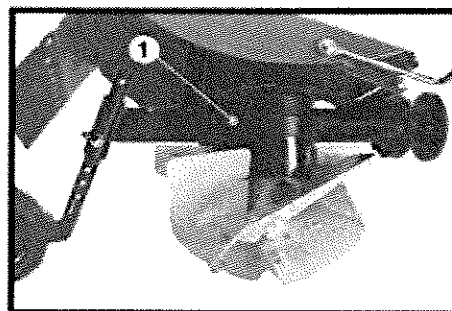

Dismantling due to deterioration and/or obsolescence.

At the end of the machine's life cycle, it must be demolished and it is important to consider the type and composition of the materials to be broken up:

1. Ferrous materials, those composed exclusively of metal, being secondary raw materials, must be taken to registered iron collection yards, after the substances listed in subsection 3 have been
2. plastics and rubber materials, being classed as comparable to urban waste in accordance with community law, may be taken directly to the public refuse department.
3. exhaust oils being classed as special waste and as a result, their collection, transport and disposal must be entrusted to the special department designated.

TAKE NOTICE: as the legislation governing waste disposal is continually being changed and updated, the user must keep up to date with the regulations in force when the machine is demolished. Future regulations could differ from those listed above, which are purely informative and general.

Berta S.r.l. remains at your disposal should you require further information, spare parts or technical assistance.